



County of Santa Cruz

GENERAL SERVICES DEPARTMENT

701 OCEAN STREET, SUITE 330, SANTA CRUZ, CA 95060-4073

(831) 454-2210 FAX: (831) 454-2710 TDD: (831) 454-2123

NANCY GORDON, DIRECTOR

April 9, 2010

Agenda: April 13, 2010

Board of Supervisors
County of Santa Cruz
701 Ocean Street
Santa Cruz, CA 95060

Santa Cruz Veterans Memorial Building Repair Project

Dear Members of the Board:

At your Board's March 23, 2010 meeting, you received a status report from the General Services and Parks Departments on the progress of the building evaluation and efforts of staff to work with the Veterans Memorial Building Board of Trustees during the closure period. At that time, General Services was directed to return today with the preliminary report on engineering findings and initial recommendations on various repair options and costs estimates for your Board's consideration. The Parks Department is providing a separate report on today's agenda for your Board's consideration on a possible contract with the Veterans Memorial Building Board of Trustees during the closure period.

Attachment 1 is a report detailing preliminary findings of the seismic evaluation from the Streeter Group and William Fisher Architect. This evaluation supports their original opinion that the building represents a risk to occupants during a seismic event. The report identifies structural deficiencies that do not meet minimum life safety performance standards, in particular the requirement that the lateral force resisting system have a complete load path to resist seismic loads (meaning that every element which resists seismic loads from the roof down to the foundation is adequately fastened together). In addition to the structural findings, preliminary recommendations are made for repairing the identified deficiencies. Additional geotechnical and materials testing work is still underway and is expected to be available before the end of the month at the latest, which may necessitate an update to the anticipated repair strategy.

As discussed in the report, the recommended conceptual repair plan brings the building up to a minimum life safety standard. This work plan includes repair of the existing distressed concrete, providing complete lateral load resisting load paths to resist seismic loads where required, strengthening some existing structural elements, and modifications to the existing foundation system. Based on local contractor experience in this type of renovation, a cost estimate of the recommended repair strategy developed for planning purposes is approximately \$1,400,000, which includes construction, architectural engineering and administrative costs. As this is a preliminary evaluation, assumptions were made by the engineer regarding certain design criteria. A more precise analysis will be necessary for a final repair plan to be developed, including preliminary exploration of the rear retaining wall footings and more investigation of the rear footings under the stage. Associated geotechnical studies will also be required as part of the

preparation of biddable repair plans, particularly in view of the likely finding of liquefiable soils in the area. Additional review and approval of any repair plan is required by a regional committee of the State Historic Preservation Office before proceeding. It is estimated that actual repair work will take between four and six months, dependent upon identification of conditions.

Your Board had requested information regarding potential interim measures that could be taken to reopen the building for occupancy prior to final repairs being implemented. Due to the identified deficiencies, the installation of any such measures would basically entail similar work as that described in the repair plan. However, this work would only protect the building itself from further major damage and not allow the desired safe re-occupancy prior to final repairs.

At your Board's March 23, 2010 meeting, direction was given by your Board to include an analysis of the written opinion of the building's condition given by Mr. Paul Cox, a civil engineer to the veterans post commander (Attachment 2). Mr. Cox had made a site visit on January 27, 2010 with the County's architect and engineer. Based on his experience, Mr. Cox's letter characterized the building's spalling damage as structurally insignificant that could if left unrepaired become significant. His assessment that the building should not have been closed is based on his interpretations of the California Historic Building Code. The report of our engineers concludes that they and Mr. Cox apparently disagree on what constitutes a dangerous condition and the engineers believe that some statements made by Mr. Cox are contradictory. Taking into account Mr. Cox's various assertions, the architect and engineer remain firm in their initial opinion, and that the evaluation work performed to date substantiates the suspected structural deficiencies. The Streeter Group report's executive summary states "the building standards and codes provide a minimum standard of care for professional engineers. If the building does not meet these standards and a dangerous condition exists than it is the professional engineer's responsibility to inform the building owner or official of the dangerous condition; to accept a lesser standard is to expose potential liability or negligence". County staff concurs with the Streeter Group's statement, and will continue to work with diligence to finalize an appropriate repair strategy for reopening the building at the earliest opportunity. Further detail is provided in an appendix of the Streeter Group's report.

Additional work elements for non-structural building deficiencies are identified in the Streeter Group report but not included in the repair strategy addressing the structural deficiencies. General Services will work with Parks on cost estimates for repair of these elements, which can be handled through the department's work order system.

Given the upcoming budget uncertainties during these difficult economic times, identifying funding sources for the repair project will be challenging. General Services and Parks staff will be working closely with the CAO to develop information regarding any options for providing the necessary funding for the final repair strategy.

It is therefore RECOMMENDED that your Board:

1. Accept this report; and
2. Direct staff to work with the CAO and return on or before May 25, 2010 with information for funding the necessary repairs.

Very truly yours,



Nancy Gordon
General Services Director

RECOMMENDED:

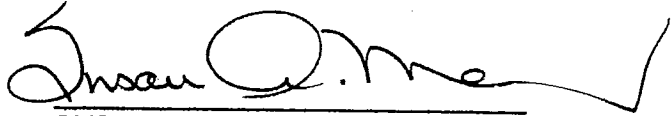

SUSAN A. MAURIELLO
County Administrative Officer

NCG

Attachments:

- 1 - Streeter Group Inc report
- 2 - March 4 letter to Robert Patton, VFW Bill Motto Post 5888, from Paul Cox

cc: CAO; County Counsel; Parks; Risk Management; Human Services Department; Santa Cruz Veterans Board of Trustees; Veterans Memorial Council, Santa Cruz City Manager, Santa Cruz City Fire Chief; Streeter Group; William Fisher Architect; Brian Bauldry; Bear Testing; Paul Cox.



Streeter Group, Inc.
Architecture, Structural Engineering

April 9, 2010

Ms. Nancy Gordon
Director
General Services Department
County of Santa Cruz
Santa Cruz, CA 95060

Re: Seismic Evaluation of the Veterans Memorial Building at 846 Front Street, Santa Cruz, CA.
Our File No: 10002

Dear Ms Gordon,

In accordance with your authorization, we have performed a preliminary seismic evaluation of the primary lateral force resisting system of the Veterans Memorial Building located at 846 Front Street, Santa Cruz, Ca.

The attached report presents our structural findings including conclusions and preliminary recommendations for the repair of deficiencies found. This report is limited to the evaluation of the primary lateral structural system and some selected non-structural elements and does not represent a complete structural analysis of the building.

Please call us if you have any questions, comments or need additional assistance.

Respectfully yours,

STREETER GROUP, INC.

Brad Streeter, SE 3724
President, Principal Engineer



Attachment: Seismic Evaluation Report

Copies: Mr. William Fisher, William Fisher Architecture
Mr. Brian Bauldry, Bauldry Engineering Inc.



Streeter Group, Inc.
Architecture, Structural Engineering

**SEISMIC EVALUATION REPORT
FOR THE EXISTING
VETERANS MEMORIAL BUILDING
LOCATED AT
846 Front Street, Santa Cruz, CA**

Prepared At The Request Of

Santa Cruz County

General Services Department

Prepared by

STREETER GROUP, INC.

April 9, 2010

(SGI Job No 10002)

21

Executive Summary:

This report was prepared in order to form a professional opinion as to whether or not the Veterans Memorial building located at 846 Front Street, Santa Cruz, California is safe to occupy during a significant earthquake. Our opinion is based on site observations, review of original construction documents, limited material and soil testing and analysis of the existing lateral force resisting system of the building. Our analysis is per the American Society of Civil Engineers (ASCE) publication 31-03 titled "Seismic Evaluation of Existing Buildings" with a minimum Life Safety design performance level.

It is our opinion that the existing, as-built condition does not meet the minimum Life Safety seismic design requirements per ASCE 31. As such, the building currently presents increased risk of life or injury to the occupants of the building in the event of a significant earthquake.

The existing building was constructed prior to 1932 and has a building footprint of approximately 140 feet by 60 feet in plan. The front half of the building consists of two floors over a basement and the rear half consists of an auditorium over basement. The exterior building walls are construction of concrete which show signs of distress. Distress includes spalling of concrete in numerous locations due to corrosion of reinforcing steel within the concrete.

On January 18th we were invited to visit the Veterans Memorial Building to observe cracking and spalling of concrete in the existing concrete pilasters and columns of the auditorium and stage addition. Based on our visual observations we formed a professional opinion that the observed distress represented a risk of life or injury to the occupants of the building should a significant seismic event occur. The County of Santa Cruz subsequently closed the building.

Since the building has been closed we have performed a structural evaluation of the building per ASCE 31. The results of this evaluation have identified structural deficiencies which do not meet the minimum Life Safety performance standards. Of particular importance is the requirement that the lateral force resisting system have a complete load path to resist seismic loads. A complete load path means that every element which resists seismic loads from the roof down all the way down to the foundation level is adequately fasten together.

Another item of structural concern is that the building appears to be situated on liquefiable soils. The existing building foundation system is not constructed in a way to resist differential settlement due to the liquefiable soils which could result in damage to the building.

We have prepared conceptual plans for what would be required to bring the building up to a minimum Life Safety performance standard. This work includes repairing the existing distressed concrete, providing complete lateral load resisting load paths to resist seismic loads where required, strengthening some existing elements, and modifications to the existing foundation system. Base on this work and associated soft cost to prepare construction documents we have estimated the probable opinion of construction cost to be approximately \$1,400,000.

The Veterans have obtained a second opinion of the observed distressed by Mr. Paul Cox. Mr. Cox has prepared a letter dated March 4, 2010 in which he explains that the deterioration of the concrete is "related simply to the age of the building and deferred maintenance". He further explains that the California Historical Building Code (CHBC)

requires correction of the unsafe condition only. Although, in another sentence states that the CHBC "requires that the structure's ability to resist wind and seismic loads be evaluated, and that unsafe conditions in the lateral-load resisting system be corrected to meet certain minimum strength". This is precisely what we have done with the evaluation of the lateral forces resisting system per ASCE 31 standards based on a minimum Life Safety performance level.

Mr. Cox and we apparently disagree with what constitutes a dangerous condition. Our initial impression of the building was that we saw an older building with structural elements which most likely do not meet current code given the age of the building. We further saw deterioration in the reinforcing steel of these elements which reduces the strength of these elements to resist seismic or laterally imposed loads to a level which appeared structurally unacceptable. This presents a dangerous condition in our opinion. Our initial opinion has been substantiated with the evaluation of the building per ASCE 31 which has confirmed structural deficiencies in the lateral force resisting system.

The building codes and standards provide a minimum standard of care for professional engineers. If the building does not meet these standards and a dangerous condition exists than it is the professional engineer's responsibility to inform the building official or building owner of the dangerous condition. To accept a lesser standard is to expose oneself to potential liability or negligence. This building is potentially used by hundreds of people at a single time and a structural failure during an earthquake would be catastrophic in terms of injury or death.

21

Table of Contents:	Page
Executive Summary.....	i
Table of Contents	iii
Scope and Intent.....	1
General Building Description	1
Comparison of ASCE 31 Design Standard with California Historical Building Code	2
Basis of Review	3
Region of Seismicity	3
Discussion of Structural Building Deficiencies	4
Discussion of Non-Structural Building Deficiencies	6
Opinion of Construction Costs of Structural Repairs	7
Temporary Shoring Feasibility.....	7
Conclusions	8

Appendix:

- A. Conceptual Repair Plans
- B. Photos
- C. Screening Checklist Phase (Tier 1)
 - 3.7.9A Basic Structural Checklist for Building Type C2A: Concrete Shear Walls with Flexible Diaphragms
 - 3.7.9AS Supplemental Structural Checklist for Building Type C2A: Concrete Shear Walls with Flexible Diaphragms.
 - 3.7.16 General Basic Structural Checklist
 - 3.8 Geologic site Hazards and Foundation Checklist
 - 3.9.1 Basic Nonstructural Component Checklist
 - 3.9.2 Intermediate Nonstructural Component Checklist
- D. Preliminary Geotechnical Assessment Letter dated March 30, 2010 Prepared by Bauldry Engineering, Inc.
- E. Mr. Paul Cox Letter dated March 4, 2010 with commentary

Scope and Intent:

The scope and intent of this report is to present our initial structural findings of our seismic evaluation of the Veterans Memorial Building per a Life Safety standard.

On January 18, 2010 we were invited to visit the Veterans Memorial Building located at 846 Front Street in Santa Cruz to observe cracking and spalling of concrete in the existing concrete pilasters and columns of the auditorium and stage addition. Based on our visual observation we prepared a letter stating it was our professional opinion that the observed distress represented a risk of injury to the occupants of the building should a significant seismic event occur. The County of Santa Cruz subsequently closed the building and retained the services of a team of consultants consisting of William Fisher Architecture, Streeter Group Inc., Bauldry Engineering Inc., and BEAR Testing Laboratory to perform a seismic evaluation of the building.

This report presents the findings of the project team based upon the American Society of Civil Engineers (ASCE) publication 31-03 titled "Seismic Evaluation of Existing Buildings". The report includes noted structural deficiencies, structural repair concepts and estimated cost of repairs for use in preliminary planning purposes only.

Final repair plans will be based upon final structural analysis and additional geotechnical investigation.

General Building Description:

The Veterans Memorial building is a landmark building located in downtown Santa Cruz, California. The building was constructed in the early 1930's and dedicated in 1932 to honor those who served in the war. The building has a footprint of approximately 140 feet x 60 feet. The front portion of the building consists of two floors and a basement while the rear portion consists of a large ballroom / auditorium over the basement below. Spaces within the building are rented for different functions such as dance and yoga studios, weddings and other special events. The basement is used as a gathering place for the Veterans. The basement includes a full commercial kitchen, pool tables and exterior patios.

Two additions / structural remodels have been added to the building. The first one we estimate occurred sometime between 1945 and 1960 which consisted of the construction of a stage addition to the rear of the building. A portion of the existing rear concrete wall was removed to accommodate this work. The next addition occurred in 1965 and consisted of removing and rebuilding the stairway located on the north side of the building along with the addition of a new elevator.

The building is constructed with non-ductile reinforced concrete, wood framing and steel beams. Building elements constructed of non-ductile concrete consist of the exterior perimeter walls, interior concrete columns and concrete spandrel beams which support the second and third floor framing of the front portion of the building. The roof is typically framed with straight 1x sheathing supported by wood trusses and rafters. The spacing of the roof trussed varies throughout the building. The first and second floors of the front portion of the building are framed with 2x12 joists supported by the concrete spandrel beams. The foundation system consists of shallow concrete footings with an interior concrete slab on grade. Concrete retaining walls form the basement perimeter walls. The front retaining wall of the basement existed prior to the construction of the building.

This wall is unreinforced and pieces of crockery and glass are visible within the face of the wall.

Original construction documents of the building and construction documents of the stairway and elevator addition were available for review. No construction documents of the stage addition have been found at this time.

Comparison of ASCE 31 Design Standard with California Historical Building Code:

ASCE 31 standard is intended to serve as a national standard and was developed from and intended to replace federal government publication FEMA 310. ASCE 31 is a comprehensive evaluation tool for assessing existing buildings and identifying building deficiencies to resist imposed seismic forces. The standard includes a three-tiered process for seismic evaluation. Findings of the first tier will dictate whether subsequent tier analysis will be required. ASCE 41 "Seismic Rehabilitation of Existing Buildings" or other design standards would be used for final structural analysis and preparation of rehabilitation plans for construction of building repairs.

ASCE 31 is based on a performance standard analysis. This differs from conventional code analysis in that factor of safeties or reductions are applied to the capacity side of the equations instead of reduction of the seismic demand per conventional code methods. Either method should produce similar results with regards to building performance.

ASCE 31 provides for two design performance levels, Life Safety or Immediate Occupancy. The intent of the Life Safety standard is to provide for a minimum standard to reduce risk of life from a design earthquake and not necessarily damage control. One could expect major structural and non-structural damage to a building engineered to a Life Safety standard after a significant seismic event. Immediate Occupancy includes a higher standard which would allow occupancy of the building immediately after a seismic event. Traditionally building codes have based their performance levels on historical performance of buildings and with the recognition that new buildings can be engineered to a higher seismic demand with relatively little extra cost of construction to provide for some damage control beyond the minimum Life Safety standard.

The California Historical Building Code (CHBC) is included as part 8 of the California Building Code. The CHBC provides terms such as "imminent treat" or "distinct hazard" to help clarify when an unsafe condition exists but does not limit a building to be determined unsafe as defined in the regular code.

Structural evaluation of the building per the CHBC is to be in accordance to the 1995 edition of the California Building Code (CBC) with a 0.75 times reduction in required seismic forces. This reduction allows for lower seismic design standard to allow preservation of historical buildings when compared to current seismic code requirements. This reduction represents a minimum Life Safety performance level, similar to ASCE 31 design performance.

It is our opinion that either ASCE 31 or the CHBC could be used for the seismic evaluation of the Veterans Memorial building. Both standards provide for a minimum Life Safety performance level. The method of analysis is somewhat different but the end result is the same. Both methods require a complete load path to resist seismic forces which is of utter importance for building performance. ASCE 31 provides comprehensive

structural check lists specifically developed for evaluation of existing buildings whereas CHBC refers to regular code provisions. Both standards encourage the professional judgment of the engineer when evaluating existing buildings due to their use of historical materials and building systems.

Basis of Review:

Our analysis was based on the following information:

- Review of original construction documents. These documents consisted of:
Original Architectural and Structural plans prepared by Davis-Pearce Co. consisting of sheets A-1 through A-10 and S1 through S4. The documents have no legible date with the exception of the County surveyor map dated November 1927
- Review of original construction documents for the new concrete stair and elevator to replace an existing wood framed stairs. These documents were prepared by Mr. Richard Huyck & Associates Engineers and consists of 10 sheets dated 12-28-65
- Several site observations to document existing conditions.
- Geotechnical review conducted by Bauldry Engineering Inc.
- Selected material testing and rebar surveys conducted by BEAR Testing Laboratory.

Region of Seismicity:

This building is located in a highly seismically active region.

Mapped active or potentially active faults that may significantly affect the site are:

- San Gregorio Fault, type A fault, 16 kilometers from the building.
- San Andreas Fault, type A, 17.5 kilometers from the building
- Tularcitos Fault, type B fault, less than 10 kilometer from the building.
- Zayante-Vergeles Fault, type B, 12.5 kilometers from the building.

The faults noted above are based on review of the document titled "Maps Of Known Active Faults Near-Source Zones in California And Adjacent Portions Of Nevada" prepared by the California Department of Conservation Division of Mines and Geology and published February 1998.

The proximity of the building to these faults implies that one can expect a significant earthquake will occur during the lifetime of the building with a 10 percent chance of exceedance in 50 years. The above reference notes the San Andreas fault as having a maximum earthquake with a magnitude capability of 7.9 and a slip rate of 24 mm/yr.

Discussion of Structural Building Deficiencies:

The noted structural deficiencies are based on ASCE 31 tier one analysis and additional tier two analysis as required. See appendix A for conceptual repair plans with grid line references and appendix B for photos.

Building Systems – General

- **Lateral Load Path:** The single most important structural requirement in any structure that resist lateral loads is that the structural elements be connected together in a manner to provide a complete seismic load path from the roof to the supporting soils below. A complete load path includes that the building elements which generate seismic forces are properly connected to horizontal diaphragms which in turn are connected to vertical resisting elements, i.e. shear walls and moment frames, which then transfer the seismic loads down to the building foundation and finally into the supporting soil.

Load path deficiencies of the Veterans Memorial building include:

- Roof diaphragm connection to the perimeter concrete shear walls. Visible gaps with no connection are visible between perimeter roof rafter / ledger and concrete walls. See photos one and two.
- Lack of connection of roof diaphragm to shear wall along grid six.
- Lack of positive connection between shear walls as load is transferred through floor framing along grid 6.
- **Deterioration of Concrete:** Exterior skin of the concrete has spalled in several locations due to corrosion of reinforcing steel. See photos three through eight, eleven and twelve.

Building Systems - Configuration:

- **Weak Story:** This provision requires that the lateral strength of the lateral force resisting elements in the story located either above and below are not less than 80 percent of the strength of the lateral force elements in the given story being considered. The intent of this provision is to control inelastic deformation in a weak story which might lead to partial or total collapse of the story. The existing steel frame along grid 6 and the existing concrete columns at the ground level of grid 8 are weak elements compared to the solid walls above. Additional structural strengthening of these elements will be required.
- **Vertical Discontinuities:** Shear walls along grids 6 and 8 are discontinuous at the bottom stories due to change from shear walls to either moment steel or concrete frame. This potentially results in a weak or soft story. Additional strengthening will be required at these locations to resist the required imposed seismic loads.

Lateral-Force Resisting System:

- **Reinforcing Steel:** Based on review of original construction documents the concrete shear walls do not appear to meet minimum reinforcing steel requirements. If walls do not have sufficient reinforcing steel, they will have a limited capacity in resisting seismic forces. The wall also will behave in a non-ductile manner for inelastic forces. Additional analysis will be performed once final rebar investigation work has been completed. Compliance with this requirement will be based on engineering judgment once final analysis has been completed.

- Steel Moment Frames: Existing steel frame located at the basement level of grid six does not appear to be adequate to support required imposed lateral loads. Additional analysis is required for rehabilitation.
- Concrete Moment Frames: Shear Stress Check: The shear stress in the existing concrete frames along grids 3, 5 and grid 8 is greater than what is allowed for a Life Safety performance level. Additional analysis is required for rehabilitation.
- Walls in Wood-Framed Buildings – Shear Stress Check: Shear stress of existing shear walls of grid 6 is greater than the allowable given shear values by a considerable amount. Additional analysis is required for rehabilitation.
- Walls in Wood-Framed Buildings – Plaster Shear Walls: Plaster shear walls shall not be used except at the top story of multiple story building. Existing lath and plaster shear wall at grid 6 at the main story is non-compliant. . Additional analysis is required for rehabilitation.
- Walls in Wood-Framed Buildings – Walls Connected Through Floors: Existing lateral connections through floor of shear walls along grid 6 are inadequate.

Connections:

- Transfer to Shear Walls: No positive connection observed between the roof diaphragm and the exterior concrete shear walls. Additional investigation required for floor diaphragm to wall connection. See photos one and two.

Diaphragms:

- Diaphragm Continuity: Roof diaphragm steps in elevation at grids three and six. Diaphragm shear transfer not observed at these locations. See photos nine and ten of stepped roof condition.
- Cross Ties: In general the original engineer of the building appears to have attempted to tie the building together rather well with the following exception. No exterior wall to roof connection tie is noted on the plans along grid A. Additional inspection required.
- Spans: Existing roof diaphragm consists of straight sheathing. Straight-sheathed diaphragms are flexible and weak relative to other types of diaphragms. Tier two analysis indicates that the existing roof diaphragm is inadequate.

Foundations:

- Based on research by Bauldry Engineering Inc. this site is located on liquefiable soils. Liquefiable soils may result in excessive differential settlement of the building during a significant seismic event. Building foundations located on liquefiable soils typically consist of either deep foundations, concrete mat foundations or a rigid grid to mitigate differential settlement.

The existing building foundation consists of shallow perimeter concrete footings and isolated interior concrete footings. This foundation system is potentially subject to excessive differential settlement which presents risk of building failure. Structural repairs would include the addition of additional shallow foundations located between the existing isolated footings to create a rigid grid foundation.

- See Appendix D for Preliminary Geotechnical Assessment letter by Bauldry Engineering, Inc. dated March 30, 2010 for description of underlying soil conditions and additional information.
- The front retaining wall adjacent to Front Street was pre-existing prior to the construction of the Veterans Memorial building. Rebar survey indicates that this wall is unreinforced. Pieces of crockery and glass are visible within the face of the wall. We suspect that this wall was constructed with a lime-sand mortar instead of cement which was common in early concrete construction. At this time we anticipate that strengthening of the wall will be required. Proposed strengthening consists of shotcreting the face of the existing wall along with foundation strengthening. See attached repair sketches, appendix A.

Discussion of Non-Structural Building Deficiencies:

Evaluation of non-structural items is part of ASCE 31. Results of the evaluation of non-structural items are noted below but not included as part of the proposed scope of structural repairs.

Basic Nonstructural Component Checklist:

Partitions:

- There are 2 unreinforced clay tile masonry walls in the boiler room in the basement. These walls present a risk of failure during a seismic event. One of the walls has a large diagonal crack.

Ceiling Systems:

- The interior wall partitions in the Veterans services area in the southwest corner of the first floor stop just above the suspended ceiling and are not braced to the floor above or other portion of the structure.

Light Fixtures:

- One emergency light fixture in the basement is suspended by electrical conductors from the ceiling.

Parapets, Cornices, Ornamentation, and Appendages:

- Anchors attaching the ornamental metal balconies show signs of deterioration and/or rusting.

Building Contents and Furnishing:

- There were many tall narrow book cases and displaced cases throughout the structure, most but not all, were not anchored to the adjacent wall.

Mechanical and Electrical Equipment:

Attached Equipment:

- The ceiling mounted mechanical equipment in the basement is not laterally braced.
- Lights in the auditorium, Club Room and basement bathroom are chain or pendent hung and not braced.
- Some anchors supporting mechanical equipment are not attached properly.

- Some attachments of electrical equipment are not attached properly.

Piping:

Flexible Coupling:

- All utilities enter the building from underground. No flexible coupling between the building and the street utilities was found.

Hazardous Materials Storage and Distribution:

- Large quantities of cleaners and paints were stored in the basement. None of these materials were restrained.

Masonry Chimneys

- The clay tile flue from the fireplace at the Club Room on the 2nd floor did not appear to be braced to the roof framing or diaphragm.

Opinion of Construction Cost of Structural Repairs:

Based upon our structural findings we have prepared the attached conceptual repair plans, see appendix A. Mr. Keith Henderson and Mr. Shawn Williams of Barry Swenson Builder have graciously met with us to discuss the scope of repair work and assist in the preparation of a preliminary opinion of construction costs. Barry Swenson Builder has extensive experience with this type of project.

In addition to construction costs we have estimated soft costs for the final preparation of repair plans.

Architectural and Structural Engineering Service: (Includes electrical and mechanical services if needed)	\$ 160,000
Additional Geotechnical Engineering and Geology Service:	\$ 35,000
Design Contingencies:	\$ 35,000
Subtotal of Soft Costs:	\$ 230,000
Opinion of Construction Costs:	\$1,170,000
Total Project Estimated Repair Costs:	\$1,400,000

Construction costs noted above do not include any permitting costs or construction administration costs. Estimated costs are for planning purposes only.

Temporary Shoring Feasibility:

We have studied the feasibility of shoring the building with the intent that the building could be occupied until final repairs can be completed. Based on site constraints, difficulties of bracing the building, and potential liquefiable soils it is our opinion that it is not economically feasible to temporarily brace this building.

Conclusions:

It is our opinion that the Veterans Memorial building as constructed presents a risk of life or injury to the occupants of the building during a significant seismic event.

The results of this evaluation phase have confirmed our original opinions that this building presents a risk to the occupants of the building during a seismic event. Based on analysis we have found that the auditorium concrete pilasters are stronger than anticipated given the amount of deterioration observed. On the other hand the calculated strength of the concrete piers supporting the rear wall of the stage are weaker than anticipated and can be classified as a dangerous condition based on the definition of a dangerous building per the 1997 "Uniform Code of the Abatement of Dangerous Buildings".

11 ✓

At this stage our evaluation is based on review of original construction documents, assistance of Bauldry Engineering Inc. and limited rebar surveys. Material testing has not been completed at this time and is required to verify the assumed strength of materials we have used. We do not anticipate results of material testing to change the proposed scope of the repair plans.

The use of the California Historical Building Code (CHBC) is applicable to protect the historical significance of the buildings. It is our opinion that the CHBC is not the only authority to classify the building as a dangerous condition. We could argue the meaning of "imminent threat" per the CHBC with regards to a seismic event but given the use of the building and the consequences of a structural collapse it is a mute point in our opinion. Building occupants would not have time to escape given a seismic event. We have identified structural deficiencies in the primary lateral load paths and as such do not recommend use of the building until these deficiencies have been repaired.

The building has some fundamental structural deficiencies which limit its ability to resist seismic loads. Of particular concern are the concrete columns under the rear wall of the stage, the lack of an adequate load path to transfer seismic loads, and the potential building settlement given the liquefiable soil conditions. These are all fixable items and once fixed the building should provide the desired performance level to protect life safety.

We have heard many times that the building withstood the Loma Preita earthquake in 1989 without any damage. We should note that the Loma Preita earthquake was not a design earthquake. The period of the strong ground motion of the Loma Preita earthquake lasted for only about seven to ten seconds which was about half of what was expected for an earthquake of that size. A design earthquake is expected to have approximately ten times the amount of ground motion, a much longer duration and about thirty times more energy. Buildings which withstood the Loma Preita earthquake will not necessarily withstand a design earthquake with a Richter scale magnitude of 7.9 or greater.

We suspect that some of the observe cracking in the concrete pilasters and columns may of been a result of the Loma Preita earthquake. Some of the cracking in the top of the concrete columns and mid-span of the concrete pilasters is located were we would suspect earthquake damage to occur. It appears that some of the areas where the concrete is spalling away may have been previously patched. This cracking could have contributed to allowing moisture into the concrete and resulted in corrosion of the reinforcing steel.

APPENDIX A

CONCEPTUAL REPAIR PLANS

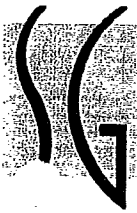

Streeter Group, Inc.

Architecture, Structural Engineering
2571 Main Street, Suite C, Soquel, CA 95073
Phone: (831) 477-1781 www.streetergroup.com

JOB 10002 - Veterans Hall
SHEET NO. Partial Roof Framing Plan
CALCULATED BY _____ DATE _____
CHECKED BY _____ DATE _____
SCALE _____

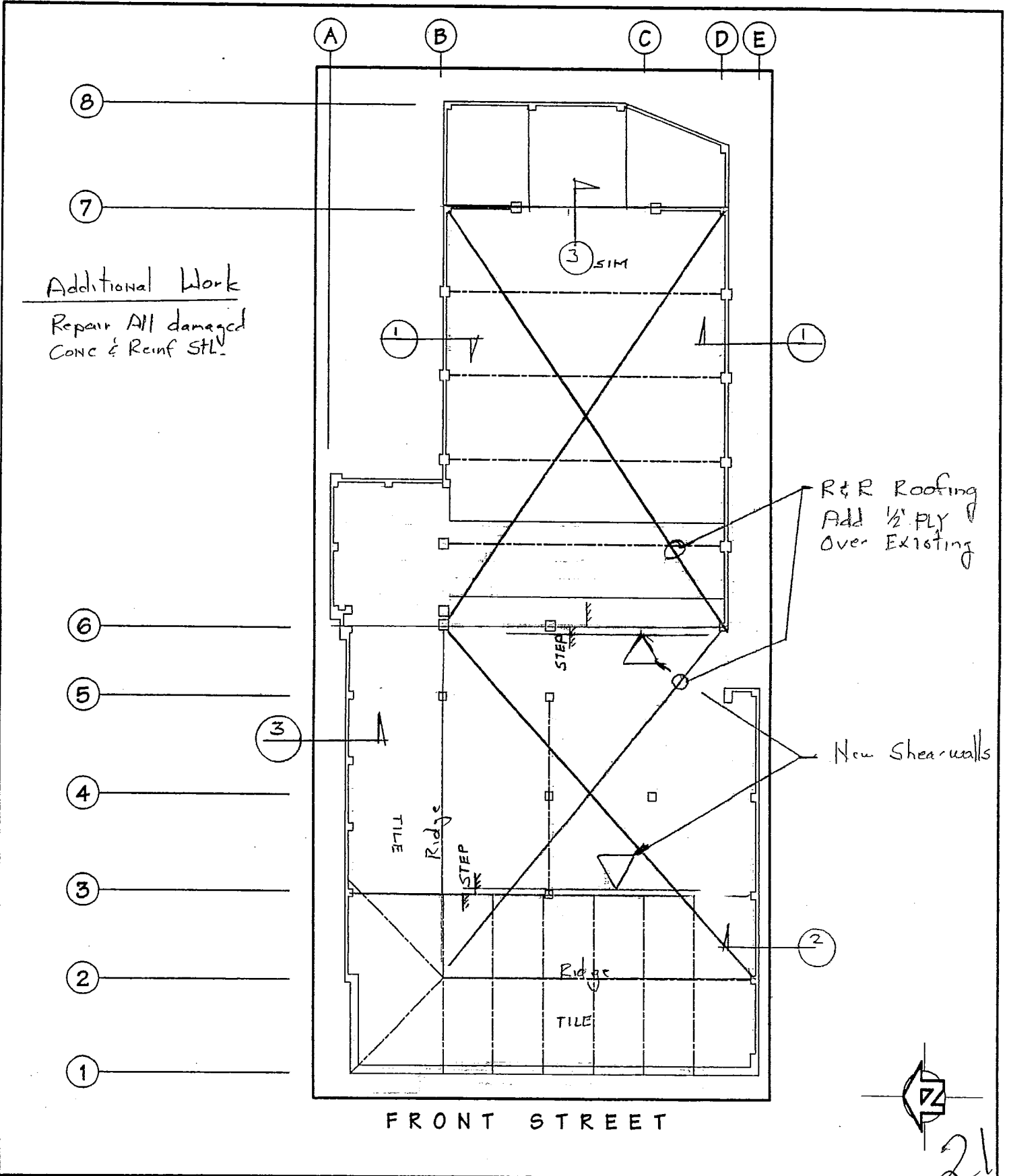



Streeter Group, Inc.

Architecture, Structural Engineering
2571 Main Street, Suite C, Soquel, CA 95073
Phone: (831) 477-1781 www.streetergroup.com

JOB 10002 - Veterans Hall
SHEET NO. Partial 2 Floor Framing Plan
CALCULATED BY _____ DATE _____
CHECKED BY _____ DATE _____
SCALE _____

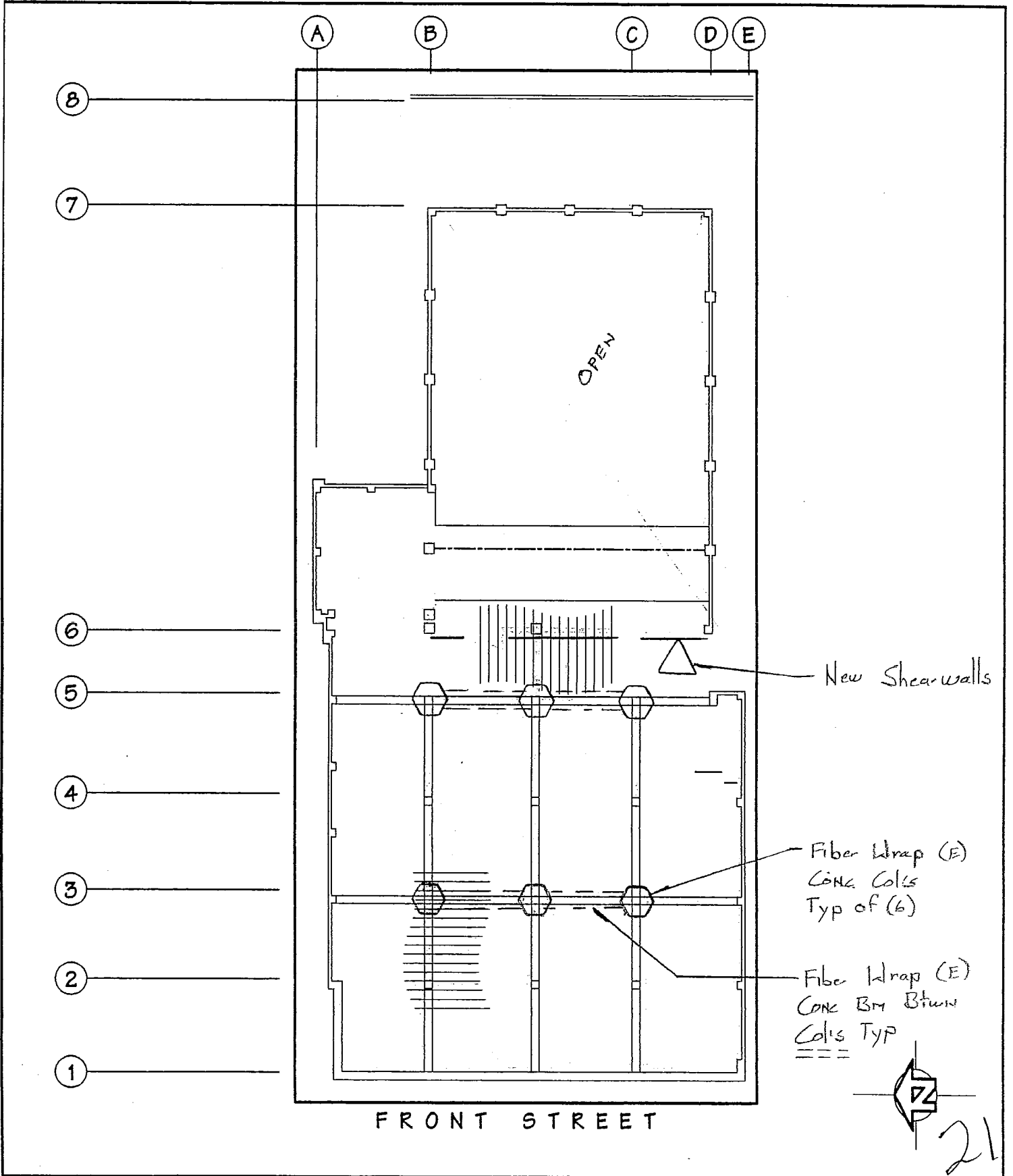



Streeter Group, Inc.

Architecture, Structural Engineering
2571 Main Street, Suite C, Soquel, CA 95073
Phone: (831) 477-1781 www.streetergroup.com

JOB 10002 - Veterans Hall
SHEET NO. Partial 1e. Floor Framing Plan
CALCULATED BY _____ DATE _____
CHECKED BY _____ DATE _____
SCALE _____

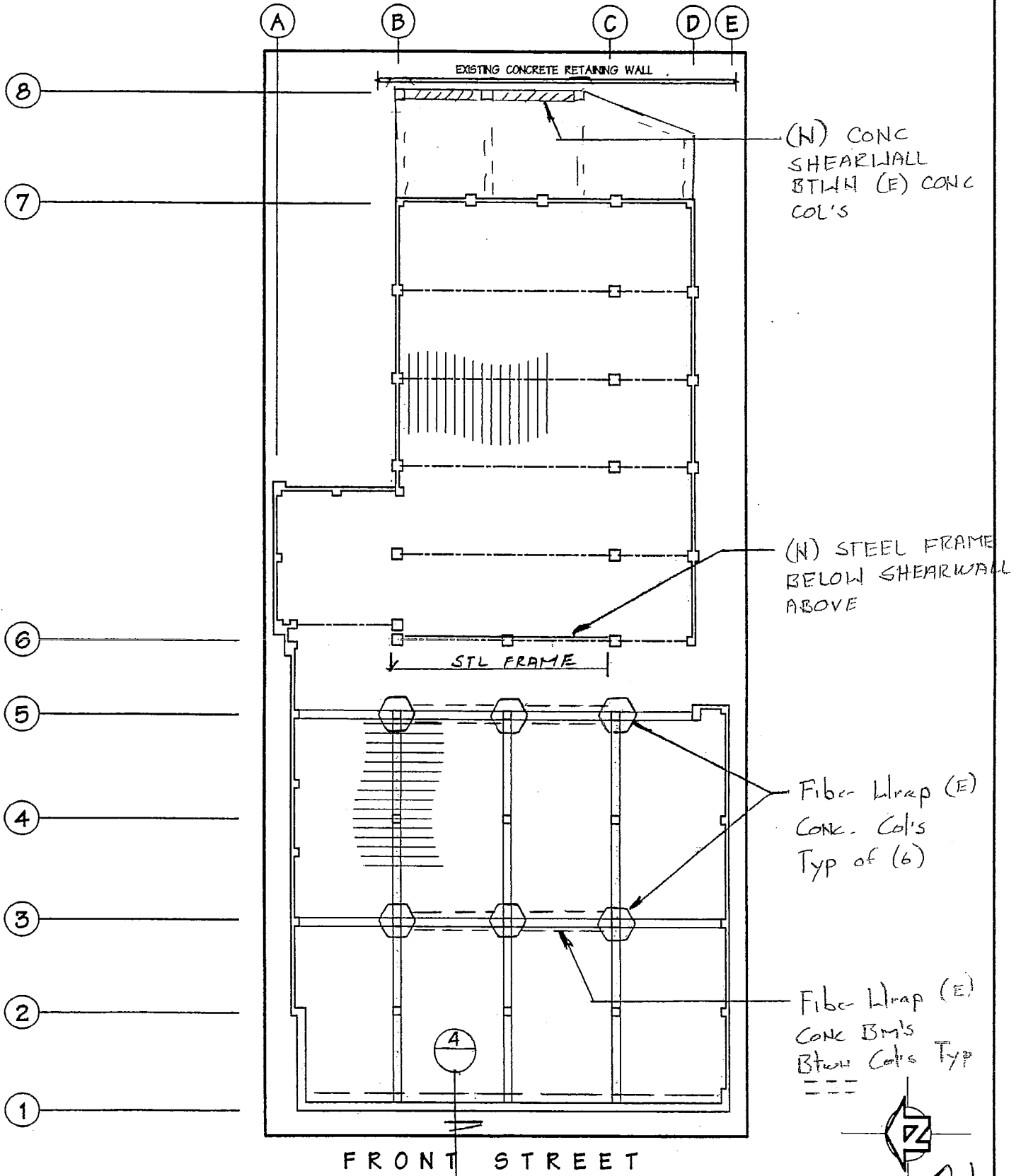

21

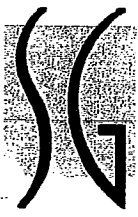

Streeter Group, Inc.

Architecture, Structural Engineering
2571 Main Street, Suite C, Soquel, CA 95073
Phone: (831) 477-1781 www.streetergroup.com

JOB 1000^o - Veterans Hall
SHEET NO. Partic. Foundation Plan
CALCULATED BY _____ DATE _____
CHECKED BY _____ DATE _____
SCALE _____

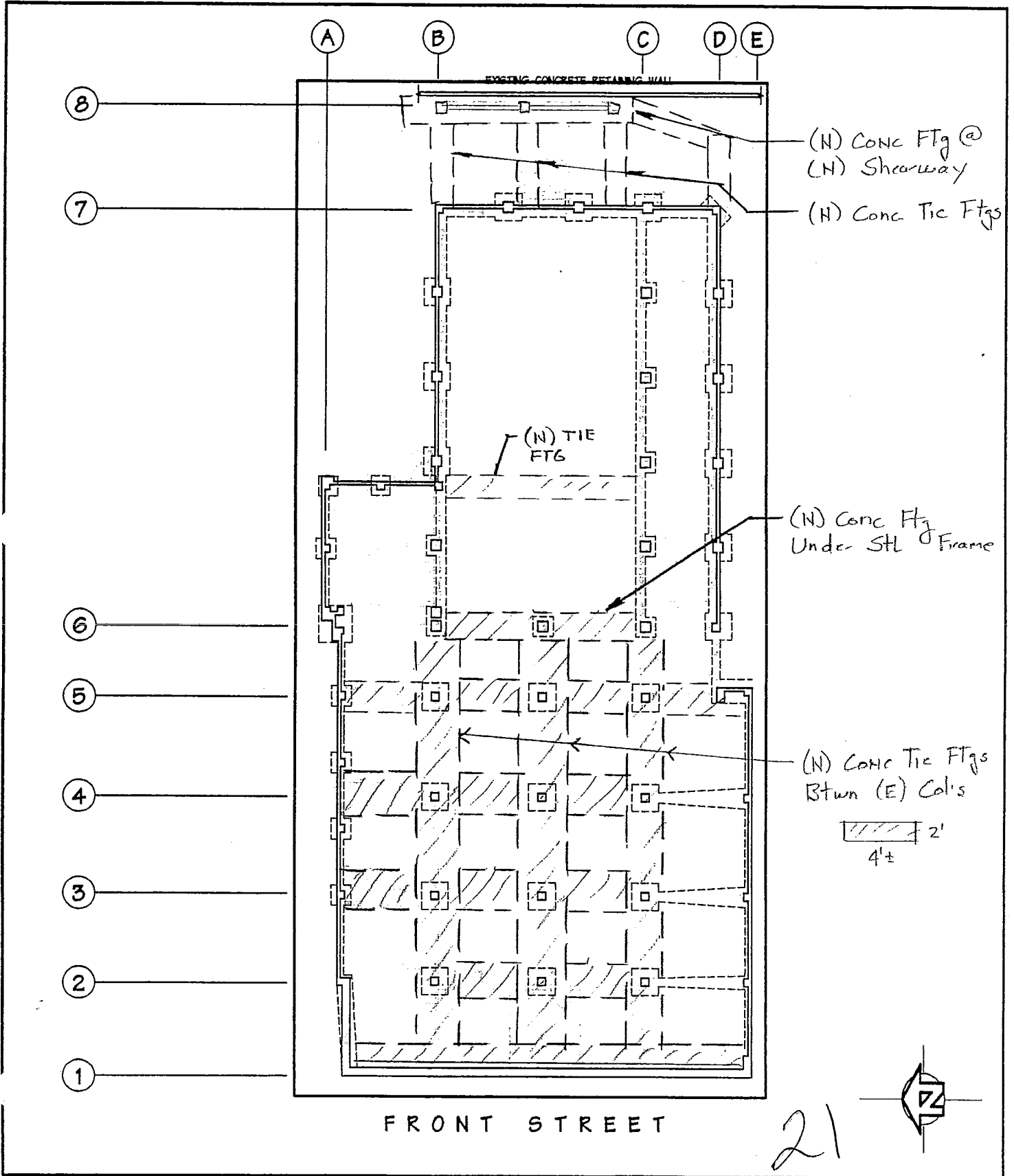

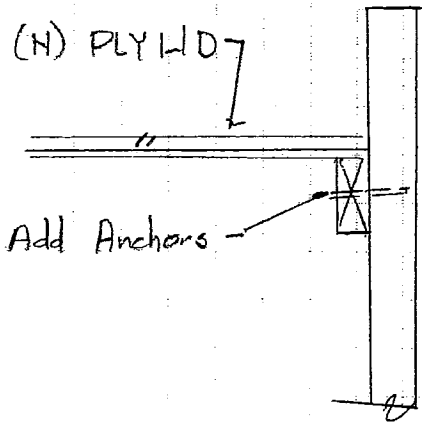
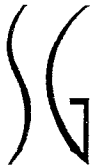

2

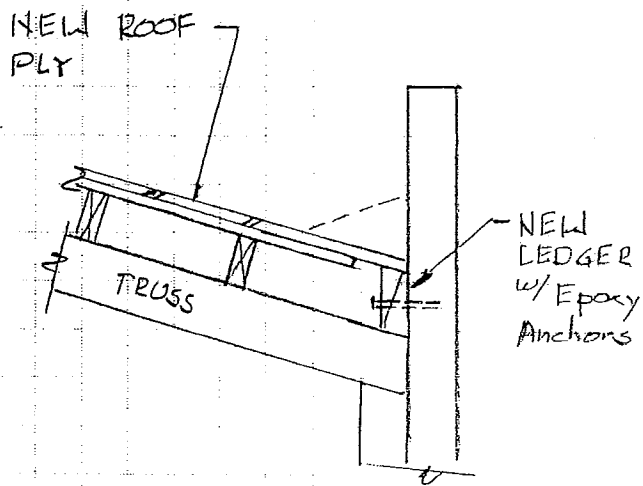

Roof Connection

1

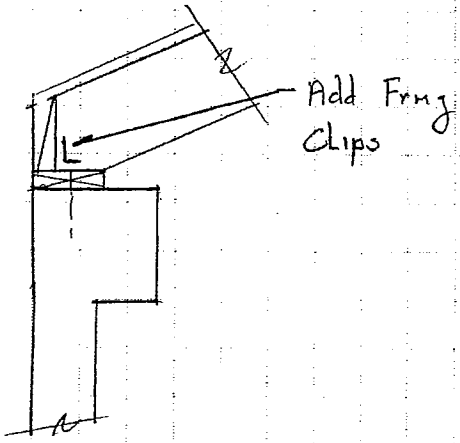

3

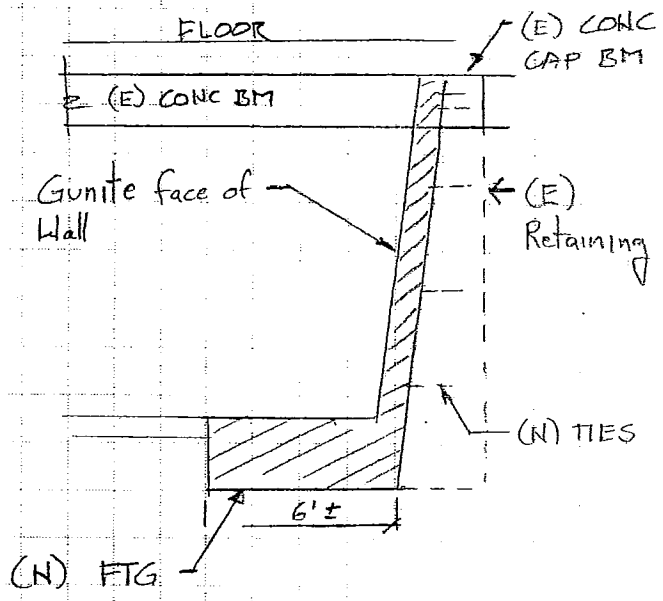

4

21

APPENDIX B

PHOTOS

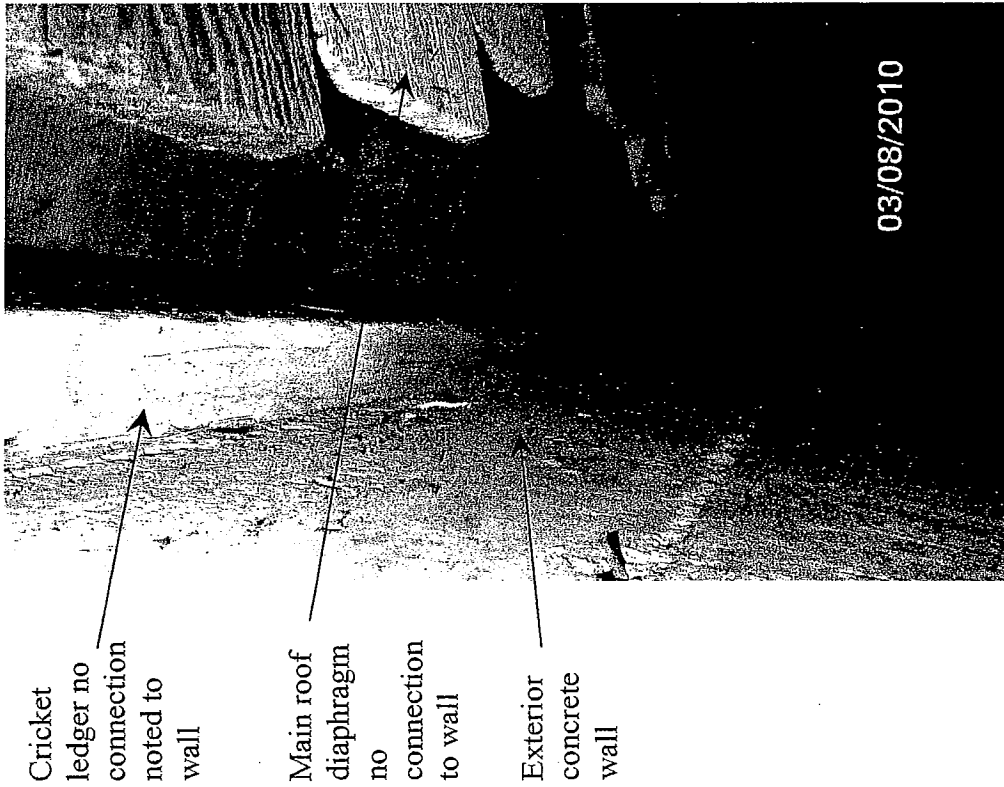

DISCONTINUITY at ROOF to WALL CONNECTION
Photo 1

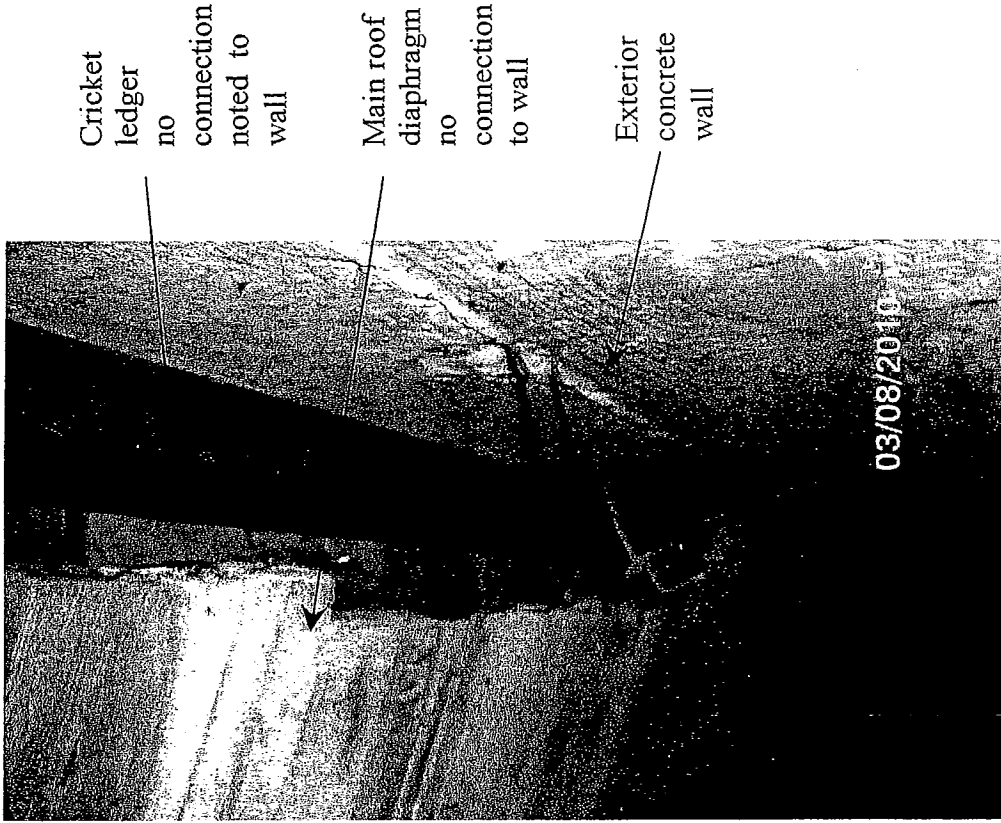

DISCONTINUITY at ROOF to WALL CONNECTION
Photo 2

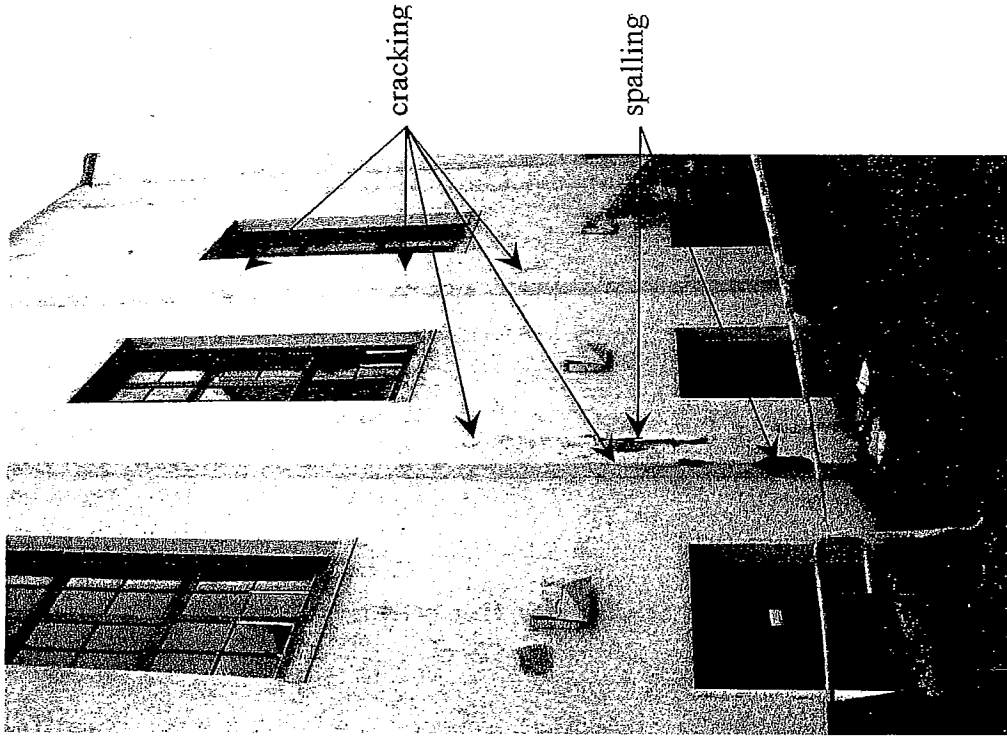

SPALLING OF CONCRETE AT PILASTER

Photo 4

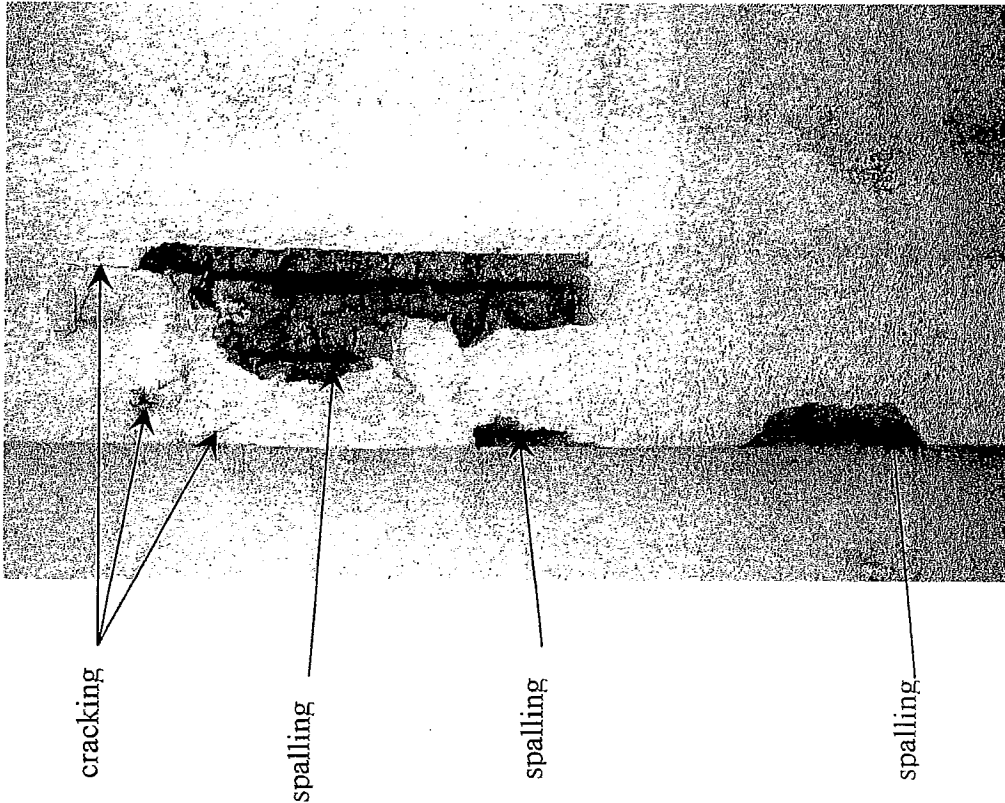

SPALLING OF CONCRETE AT PILASTER

Photo 3

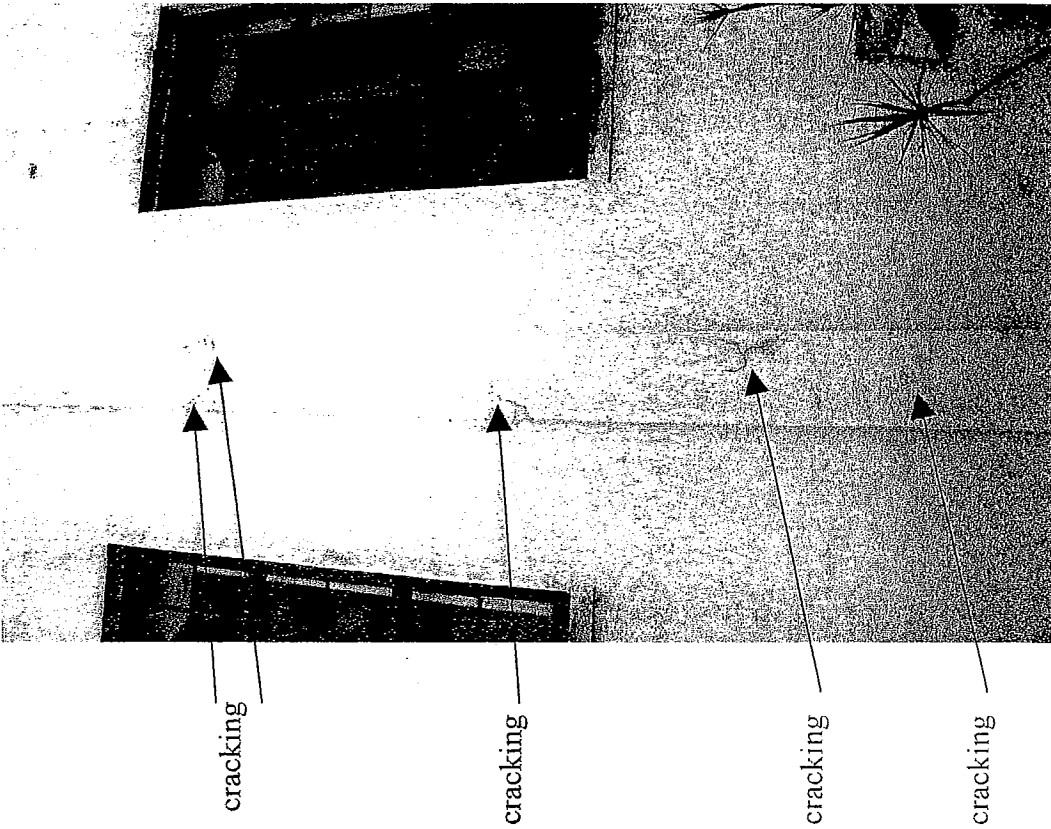

CRACKING OF CONCRETE AT PILASTER
Photo 5

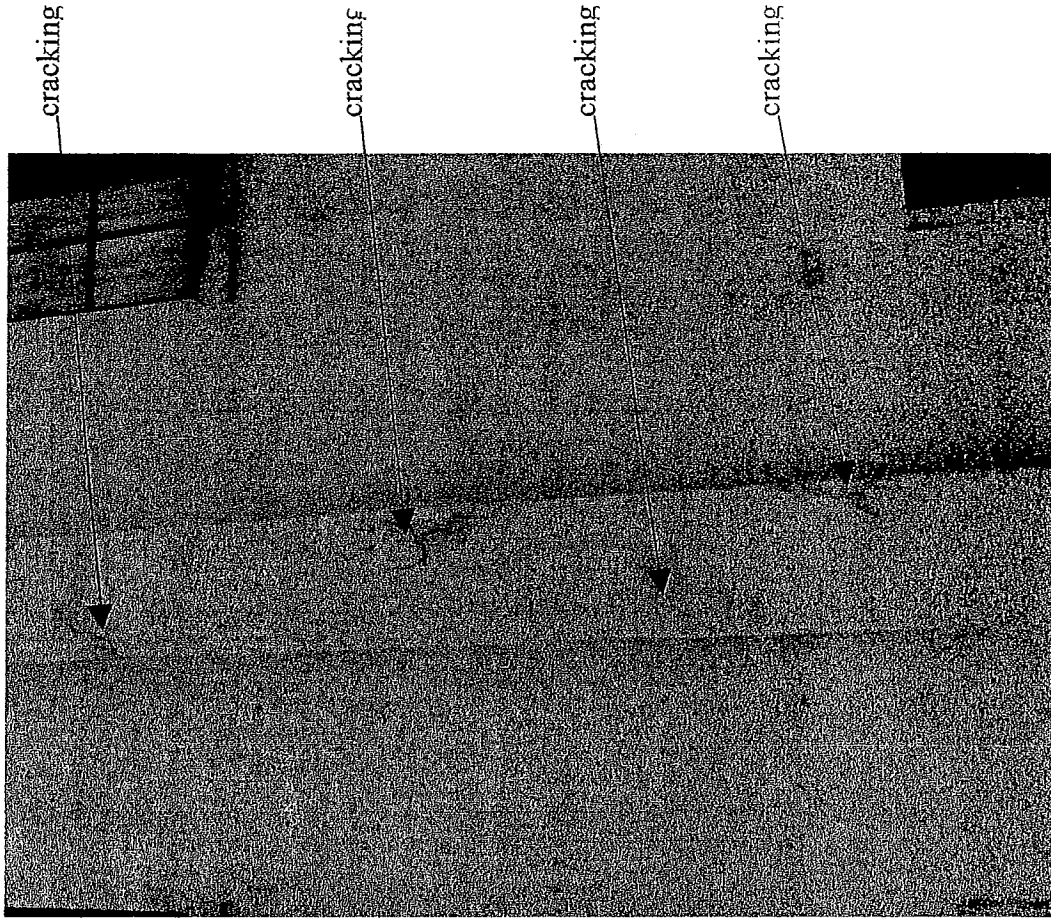

CRACKING OF CONCRETE AT PILASTER
Photo 6

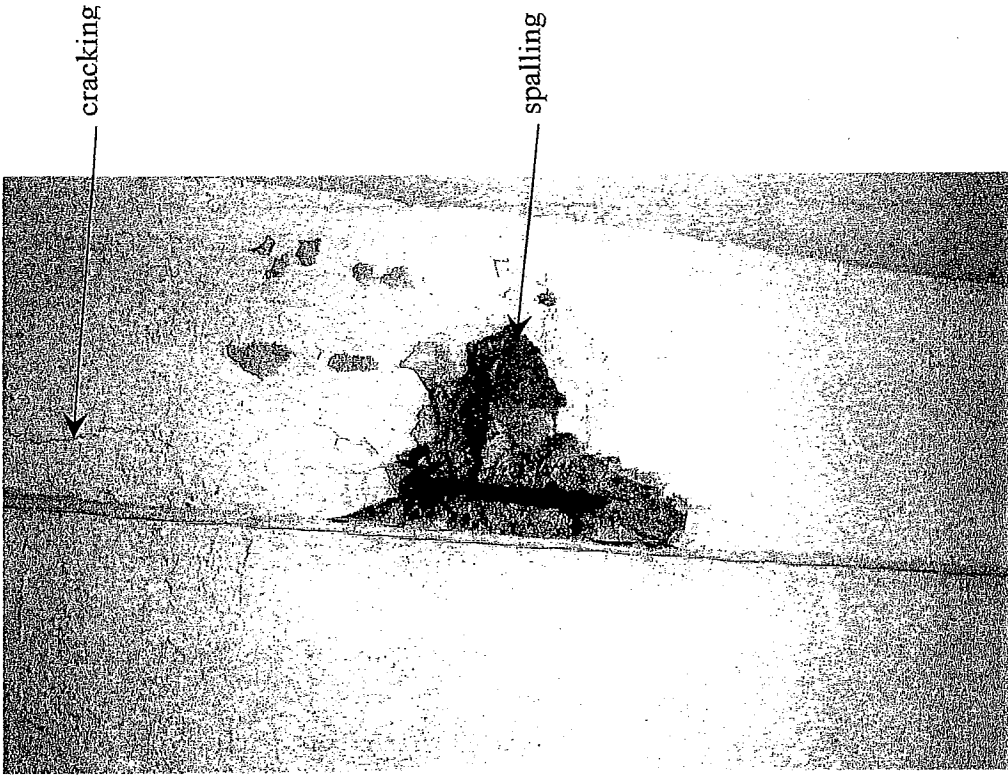

SPALLING OF CONCRETE AT PILASTER
Photo 8

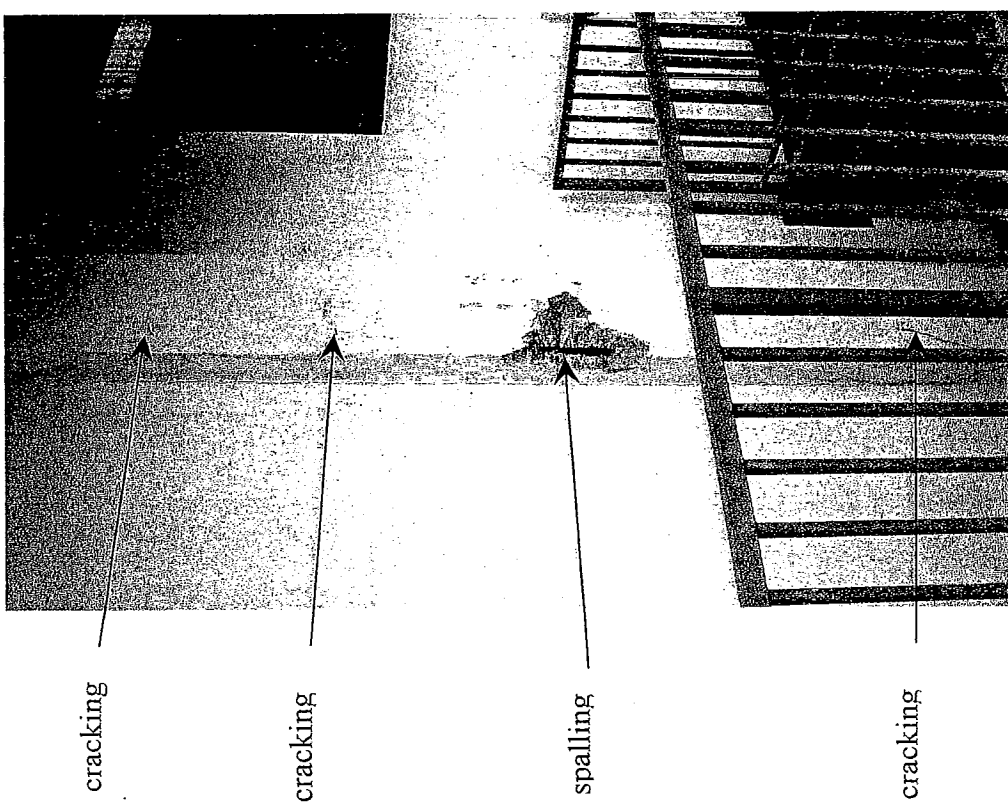

SPALLING OF CONCRETE AT PILASTER
Photo 7

Step in roof diaphragm
at Grid 3

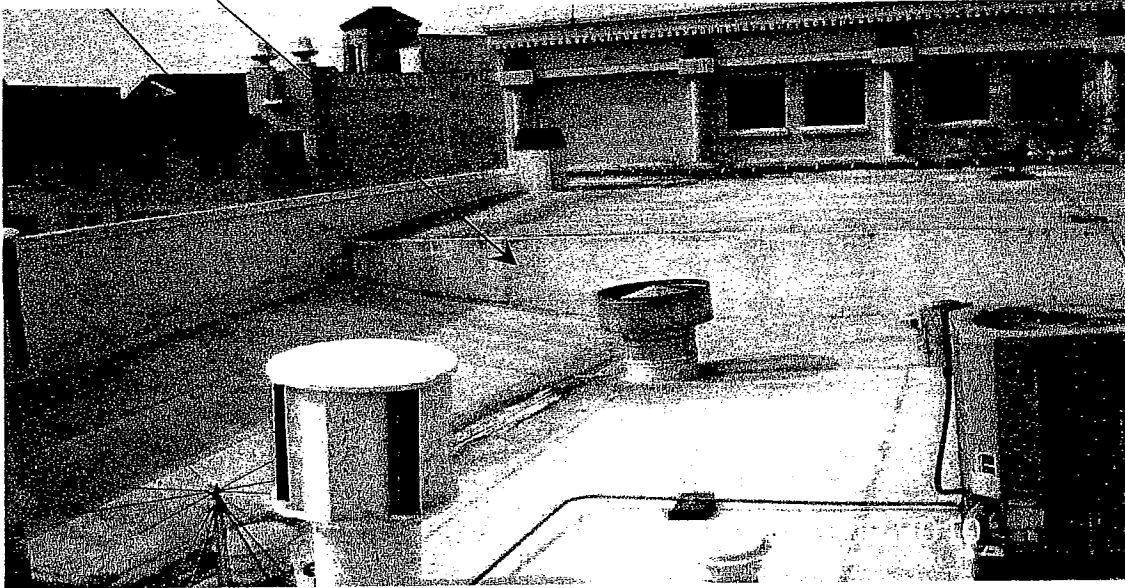

STEP IN ROOF DIAPHRAGM

Photo 9

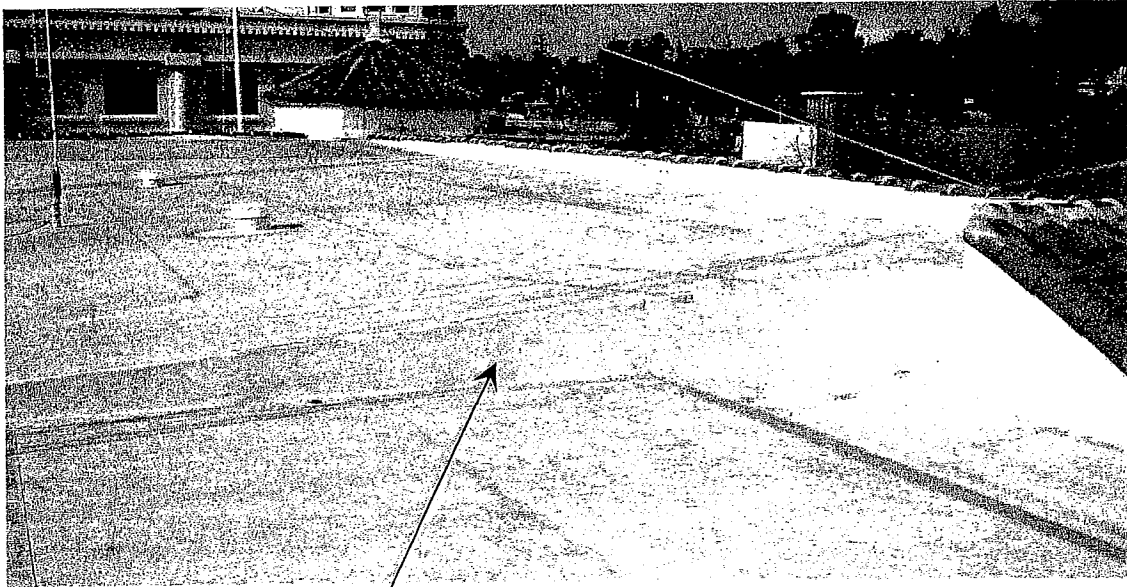

Step in roof diaphragm
at Grid 6

STEP IN ROOF DIAPHRAGM

Photo 10

Concrete Spalling

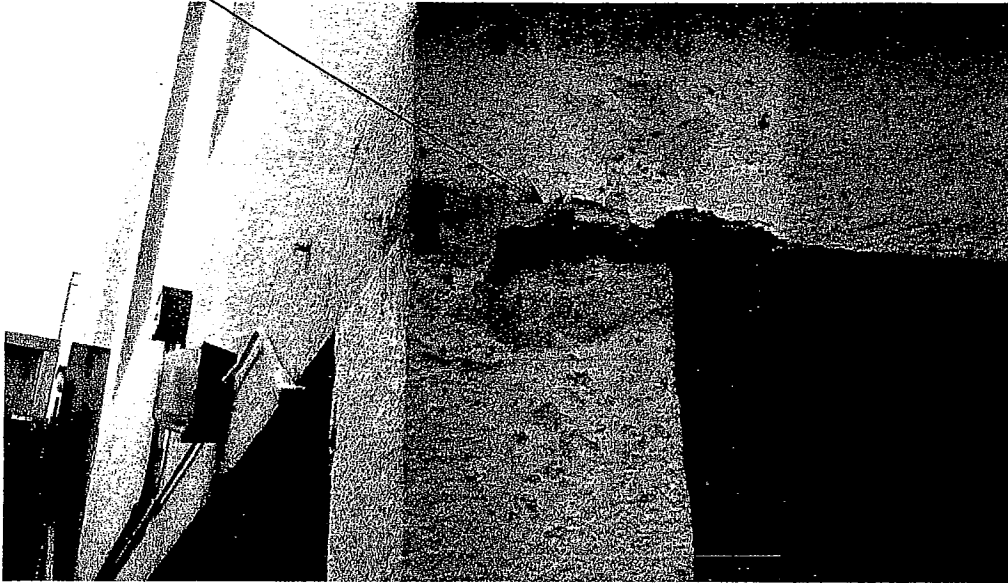

STAGE ADDITION CONCRETE COLUMN SPALLING

Photo 11

Concrete Spalling

Corrosion of Vertical
Reinforcement

Corrosion of
Horizontal
Reinforcement



STAGE ADDITION CONCRETE COLUMN
SPALLING AND REINFORCEMENT CORROSION

Photo 12

APPENDIX C

SCREENING CHECKLIST PHASE (Tier 1)

- 3.7.9A Basic Structural Checklist for Building Type C2A: Concrete Shear Walls with Flexible Diaphragms
- 3.7.9A5 Supplemental Structural Checklist for Building Type C2A: Concrete Shear Walls with Flexible Diaphragms
- 3.7.16 General Basic Structural Checklist
- 3.8 Geologic site Hazards and Foundation Checklist
- 3.9.1 Basic Nonstructural Component Checklist
- 3.9.2 Intermediate Nonstructural Component Checklist

3.7.9A Basic Structural Checklist for Building Type C2A: Concrete Shear Walls with Flexible Diaphragms

This Basic Structural Checklist shall be completed where required by Table 3-2.

Each of the evaluation statements on this checklist shall be marked Compliant (C), Non-compliant (NC), or Not Applicable (N/A) for a Tier 1 Evaluation. Compliant statements identify issues that are acceptable according to the criteria of this standard, while non-compliant statements identify issues that require further investigation. Certain statements may not apply to the buildings being evaluated. For non-compliant evaluation statements, the design professional may choose to conduct further investigation using the corresponding Tier 2 Evaluation procedure; corresponding section numbers are in parentheses following each evaluation statement.

C3.7.9A Basic Structural Checklist for Building Type C2A

These buildings have floor and roof framing that consists of wood sheathing on wood framing and concrete beams. Floors are supported on concrete columns or bearing walls. Lateral forces are resisted by cast-in-place concrete shear walls. In older construction, shear walls are lightly reinforced but often extend throughout the building. In more recent construction, shear walls occur in isolated locations and are more heavily reinforced with boundary elements and closely spaced ties to provide ductile performance. The diaphragms consist of wood sheathing or have large aspect ratios and are flexible relative to the walls. Foundations consist of concrete spread footings or deep pile foundations.

Building System

- C (NC) N/A LOAD PATH: The structure shall contain a minimum of one complete load path for Life Safety and Immediate Occupancy for seismic force effects from any horizontal direction that serves to transfer the inertial forces from the mass to the foundation. (Tier 2: Sec. 4.3.1.1)
- (C) NC N/A ADJACENT BUILDINGS: The clear distance between the building being evaluated and any adjacent building shall be greater than 4 percent of the height of the shorter building for Life Safety and Immediate Occupancy. (Tier 2: Sec. 4.3.1.2)
- (C) NC N/A MEZZANINES: Interior mezzanine levels shall be braced independently from the main structure, or shall be anchored to the lateral-force-resisting elements of the main structure. (Tier 2: Sec. 4.3.1.3)
- (C) NC N/A WEAK STORY: The strength of the lateral-force-resisting system in any story shall not be less than 80 percent of the strength in an adjacent story, above or below, for Life Safety and Immediate Occupancy. (Tier 2: Sec. 4.3.2.1)
- (C) NC N/A SOFT STORY: The stiffness of the lateral-force-resisting system in any story shall not be less than 70 percent of the lateral-force-resisting system stiffness in an adjacent story above or below, or less than 80 percent of the average lateral-force-resisting system stiffness of the three stories above or below for Life Safety and Immediate Occupancy. (Tier 2: Sec. 4.3.2.2)
- (C) NC N/A GEOMETRY: There shall be no changes in horizontal dimension of the lateral-force-resisting system of more than 30 percent in a story relative to adjacent stories for Life Safety and Immediate Occupancy, excluding one-story penthouses and mezzanines. (Tier 2: Sec. 4.3.2.3)
- (C) NC N/A VERTICAL DISCONTINUITIES: All vertical elements in the lateral-force-resisting system shall be continuous to the foundation. (Tier 2: Sec. 4.3.2.4)

Screening Phase (Tier 1)

- (C) NC N/A MASS: There shall be no change in effective mass more than 50 percent from one story to the next for Life Safety and Immediate Occupancy. Light roofs, penthouses, and mezzanines need not be considered. (Tier 2: Sec. 4.3.2.5)
- (C) NC N/A DETERIORATION OF WOOD: There shall be no signs of decay, shrinkage, splitting, fire damage, or sagging in any of the wood members, and none of the metal connection hardware shall be deteriorated, broken, or loose. (Tier 2: Sec. 4.3.3.1)
- C (NC) N/A DETERIORATION OF CONCRETE: There shall be no visible deterioration of concrete or reinforcing steel in any of the vertical- or lateral-force-resisting elements. (Tier 2: Sec. 4.3.3.4)
- C NC (N/A) POST-TENSIONING ANCHORS: There shall be no evidence of corrosion or spalling in the vicinity of post-tensioning or end fittings. Coil anchors shall not have been used. (Tier 2: Sec. 4.3.3.5)
- (C) NC N/A CONCRETE WALL CRACKS: All existing diagonal cracks in wall elements shall be less than 1/8 inch for Life Safety and 1/16 inch for Immediate Occupancy, shall not be concentrated in one location, and shall not form an X pattern. (Tier 2: Sec. 4.3.3.9)

Lateral-Force-Resisting System

- (C) NC N/A REDUNDANCY: The number of lines of shear walls in each principal direction shall be greater than or equal to 2 for Life Safety and Immediate Occupancy. (Tier 2: Sec. 4.4.2.1.1)
- (C) NC N/A SHEAR STRESS CHECK: The shear stress in the concrete shear walls, calculated using the Quick Check procedure of Section 3.5.3.3, shall be less than the greater of 100 psi or $2\sqrt{f'_c}$ for Life Safety and Immediate Occupancy. (Tier 2: Sec. 4.4.2.2.1)
- C (NC) N/A REINFORCING STEEL: The ratio of reinforcing steel area to gross concrete area shall be not less than 0.0015 in the vertical direction and 0.0025 in the horizontal direction for Life Safety and Immediate Occupancy. The spacing of reinforcing steel shall be equal to or less than 18 inches for Life Safety and Immediate Occupancy. (Tier 2: Sec. 4.4.2.2.2) pA-72
Need to verify spacing w/ Field results

Connections

- (C) NC N/A WALL ANCHORAGE: Exterior concrete or masonry walls that are dependent on the diaphragm for lateral support shall be anchored for out-of-plane forces at each diaphragm level with steel anchors, reinforcing dowels, or straps that are developed into the diaphragm. Connections shall have adequate strength to resist the connection force calculated in the Quick Check procedure of Section 3.5.3.7. (Tier 2: Sec. 4.6.1.1)
- C (NC) N/A TRANSFER TO SHEAR WALLS: Diaphragms shall be connected for transfer of loads to the shear walls for Life Safety and the connections shall be able to develop the lesser of the shear strength of the walls or diaphragms for Immediate Occupancy. (Tier 2 Sec. 4.6.2.1)
- (C) NC N/A FOUNDATION DOWELS: Wall reinforcement shall be doweled into the foundation for Life Safety, and the dowels shall be able to develop the lesser of the strength of the walls or the uplift capacity of the foundation for Immediate Occupancy. (Tier 2: Sec. 4.6.3.5)

21

3.7.9AS Supplemental Structural Checklist for Building Type C2A: Concrete Shear Walls with Flexible Diaphragms

This Supplemental Structural Checklist shall be completed where required by Table 3-2. The Basic Structural Checklist shall be completed prior to completing this Supplemental Structural Checklist.

Lateral-Force-Resisting System

- C NC N/A COUPLING BEAMS: The stirrups in coupling beams over means of egress shall be spaced at or less than $d/2$ and shall be anchored into the confined core of the beam with hooks of 135° or more for Life Safety. All coupling beams shall comply with the requirements above and shall have the capacity in shear to develop the uplift capacity of the adjacent wall for Immediate Occupancy. (Tier 2: Sec. 4.4.2.2.3)
- C NC N/A OVERTURNING: All shear walls shall have aspect ratios less than 4-to-1. Wall piers need not be considered. This statement shall apply to the Immediate Occupancy Performance Level only. (Tier 2: Sec. 4.4.2.2.4)
- C NC N/A CONFINEMENT REINFORCING: For shear walls with aspect ratios greater than 2-to-1, the boundary elements shall be confined with spirals or ties with spacing less than $8d_b$. This statement shall apply to the Immediate Occupancy Performance Level only. (Tier 2: Sec. 4.4.2.2.5)
- C NC N/A REINFORCING AT OPENINGS: There shall be added trim reinforcement around all wall openings with a dimension greater than three times the thickness of the wall. This statement shall apply to the Immediate Occupancy Performance Level only. (Tier 2: Sec. 4.4.2.2.6)
- C NC N/A WALL THICKNESS: Thickness of bearing walls shall not be less than $1/25$ the unsupported height or length, whichever is shorter, nor less than 4 inches. This statement shall apply to the Immediate Occupancy Performance Level only. (Tier 2: Sec. 4.4.2.2.7)

Diaphragms

- C NC N/A DIAPHRAGM CONTINUITY: The diaphragms shall not be composed of split-level floors and shall not have expansion joints. (Tier 2: Sec. 4.5.1.1)
- C NC N/A CROSS TIES: There shall be continuous cross ties between diaphragm chords. (Tier 2: Sec. 4.5.1.2)
- C NC N/A OPENINGS AT SHEAR WALLS: Diaphragm openings immediately adjacent to the shear walls shall be less than 25 percent of the wall length for Life Safety and 15 percent of the wall length for Immediate Occupancy. (Tier 2: Sec. 4.5.1.4)
- C NC N/A PLAN IRREGULARITIES: There shall be tensile capacity to develop the strength of the diaphragm at re-entrant corners or other locations of plan irregularities. This statement shall apply to the Immediate Occupancy Performance Level only. (Tier 2: Sec. 4.5.1.7)
- C NC N/A DIAPHRAGM REINFORCEMENT AT OPENINGS: There shall be reinforcing around all diaphragm openings larger than 50 percent of the building width in either major plan dimension. This statement shall apply to the Immediate Occupancy Performance Level only. (Tier 2: Sec. 4.5.1.8)
- C NC N/A STRAIGHT SHEATHING: All straight sheathed diaphragms shall have aspect ratios less than 2-to-1 for Life Safety and 1-to-1 for Immediate Occupancy in the direction being considered. (Tier 2: Sec. 4.5.2.1)

21

Screening Phase (Tier 1)

- C (NC) N/A SPANS: All wood diaphragms with spans greater than 24 feet for Life Safety and 12 feet for Immediate Occupancy shall consist of wood structural panels or diagonal sheathing. (Tier 2: Sec. 4.5.2.2)
- C NC (N/A) UNBLOCKED DIAPHRAGMS: All diagonally sheathed or unblocked wood structural panel diaphragms shall have horizontal spans less than 40 feet for Life Safety and 30 feet for Immediate Occupancy and shall have aspect ratios less than or equal to 4-to-1 for Life Safety and 3-to-1 for Immediate Occupancy. (Tier 2: Sec. 4.5.2.3)
- C NC (N/A) NON-CONCRETE FILLED DIAPHRAGMS: Untopped metal deck diaphragms or metal deck diaphragms with fill other than concrete shall consist of horizontal spans of less than 40 feet and shall have span/depth ratios less than 4-to-1. This statement shall apply to the Immediate Occupancy Performance Level only. (Tier 2: Sec. 4.5.3.1)
- (C) NC N/A OTHER DIAPHRAGMS: The diaphragm shall not consist of a system other than wood, metal deck, concrete, or horizontal bracing. (Tier 2: Sec. 4.5.7.1)

Connections

- C NC (N/A) UPLIFT AT PILE CAPS: Pile caps shall have top reinforcement and piles shall be anchored to the pile caps for Life Safety, and the pile cap reinforcement and pile anchorage shall be able to develop the tensile capacity of the piles for Immediate Occupancy. (Tier 2: Sec. 4.6.3.10)

3.7.16 General Basic Structural Checklist

This General Basic Structural Checklist shall be completed where required by Table 3-2.

Each of the evaluation statements on this checklist shall be marked Compliant (C), Non-compliant (NC), or Not Applicable (N/A) for a Tier 1 Evaluation. Compliant statements identify issues that are acceptable according to the criteria of this standard, while non-compliant statements identify issues that require further investigation. Certain statements may not apply to the buildings being evaluated. For non-compliant evaluation statements, the design professional may choose to conduct further investigation using the corresponding Tier 2 Evaluation procedure; corresponding section numbers are in parentheses following each evaluation statement.

BUILDING SYSTEM

General

- C (NC) N/A LOAD PATH: The structure shall contain a minimum of one complete load path for Life Safety and Immediate Occupancy for seismic force effects from any horizontal direction that serves to transfer the inertial forces from the mass to the foundation. (Tier 2: Sec. 4.3.1.1)
- (C) NC N/A ADJACENT BUILDINGS: The clear distance between the building being evaluated and any adjacent building shall be greater than 4 percent of the height of the shorter building for Life Safety and Immediate Occupancy. (Tier 2: Sec. 4.3.1.2)
- (C) NC N/A MEZZANINES: Interior mezzanine levels shall be braced independently from the main structure, or shall be anchored to the lateral-force-resisting elements of the main structure. (Tier 2: Sec. 4.3.1.3) *Compliant if Grid 6 wood shearwall with steel moment frame below is an adequate LFR System.*

Configuration

- C (NC) N/A WEAK STORY: The strength of the lateral-force-resisting system in any story shall not be less than 80 percent of the strength in an adjacent story, above or below, for Life Safety and Immediate Occupancy. (Tier 2: Sec. 4.3.2.1) *Grid 6 - Steel MRF*
- C (NC) N/A SOFT STORY: The stiffness of the lateral-force-resisting system in any story shall not be less than 70 percent of the lateral-force-resisting system stiffness in an adjacent story above or below, or less than 80 percent of the average lateral-force-resisting system stiffness of the three stories above or below for Life Safety and Immediate Occupancy. (Tier 2: Sec. 4.3.2.2) *Grid 8 - Concrete MRF → By observation*
- (C) NC N/A GEOMETRY: There shall be no changes in horizontal dimension of the lateral-force-resisting system of more than 30 percent in a story relative to adjacent stories for Life Safety and Immediate Occupancy, excluding one-story penthouses and mezzanines. (Tier 2: Sec. 4.3.2.3) *Grid 6 & 8, similar to weak story*
- C (NC) N/A VERTICAL DISCONTINUITIES: All vertical elements in the lateral-force-resisting system shall be continuous to the foundation. (Tier 2: Sec. 4.3.2.4)
- (C) NC N/A MASS: There shall be no change in effective mass more than 50 percent from one story to the next for Life Safety and Immediate Occupancy. Light roofs, penthouses, and mezzanines need not be considered. (Tier 2: Sec. 4.3.2.5) *Grid 6 & 8 - Shearwalls are discontinuous*
- C NC (N/A) TORSION: The estimated distance between the story center of mass and the story center of rigidity shall be less than 20 percent of the building width in either plan dimension for Life Safety and Immediate Occupancy. (Tier 2: Sec. 4.3.2.6) *Flexible Diaphragms*

21

Condition of Materials

- (C) NC N/A DETERIORATION OF WOOD: There shall be no signs of decay, shrinkage, splitting, fire damage, or sagging in any of the wood members, and none of the metal connection hardware shall be deteriorated, broken, or loose. (Tier 2: Sec. 4.3.3.1) *No deterioration observed*
- C NC (N/A) WOOD STRUCTURAL PANEL SHEAR WALL FASTENERS: There shall be no more than 15 percent of inadequate fastening such as overdriven fasteners, omitted blocking, excessive fastening spacing, or inadequate edge distance. This statement shall apply to the Immediate Occupancy Performance Level only. (Tier 2: Sec. 4.3.3.2)
- (C) NC N/A DETERIORATION OF STEEL: There shall be no visible rusting, corrosion, cracking, or other deterioration in any of the steel elements or connections in the vertical- or lateral-force-resisting systems. (Tier 2: Sec. 4.3.3.3) *No deterioration observed, mostly concealed*
- C (NC) N/A DETERIORATION OF CONCRETE: There shall be no visible deterioration of concrete or reinforcing steel in any of the vertical- or lateral-force-resisting elements. (Tier 2: Sec. 4.3.3.4) *Multiple cracks, spalling, and exposed rebar → See photos*
- C NC (N/A) POST-TENSIONING ANCHORS: There shall be no evidence of corrosion or spalling in the vicinity of post-tensioning or end fittings. Coil anchors shall not have been used. (Tier 2: Sec. 4.3.3.5)
- C NC (N/A) PRECAST CONCRETE WALLS: There shall be no visible deterioration of concrete or reinforcing steel or evidence of distress, especially at the connections. (Tier 2: Sec. 4.3.3.6)
- (C) NC N/A MASONRY UNITS: There shall be no visible deterioration of masonry units. (Tier 2: Sec. 4.3.3.7) *No deterioration noted*
- (C) NC N/A MASONRY JOINTS: The mortar shall not be easily scraped away from the joints by hand with a metal tool, and there shall be no areas of eroded mortar. (Tier 2: Sec. 4.3.3.8)
- (C) NC N/A CONCRETE WALL CRACKS: All existing diagonal cracks in wall elements shall be less than 1/8 inch for Life Safety and 1/16 inch for Immediate Occupancy, shall not be concentrated in one location, and shall not form an X pattern. (Tier 2: Sec. 4.3.3.9) *Some single diagonal cracks, < 1/8"*
- (C) NC N/A REINFORCED MASONRY WALL CRACKS: All existing diagonal cracks in wall elements shall be less than 1/8 inch for Life Safety and 1/16 inch for Immediate Occupancy, shall not be concentrated in one location, and shall not form an X pattern. (Tier 2: Sec. 4.3.3.10) *None observed*
- C NC (N/A) UNREINFORCED MASONRY WALL CRACKS: There shall be no existing diagonal cracks in wall elements greater than 1/8 inch for Life Safety and 1/16 inch for Immediate Occupancy or out-of-plane offsets in the bed joint greater than 1/8 inch for Life Safety and 1/16 inch for Immediate Occupancy, and shall not form an X pattern. (Tier 2: Sec. 4.3.3.11)
- C NC (N/A) CRACKS IN INFILL WALLS: There shall be no existing diagonal cracks in the infilled walls that extend throughout a panel greater than 1/8 inch for Life Safety and 1/16 inch for Immediate Occupancy, or out-of-plane offsets in the bed joint greater than 1/8 inch for Life Safety and 1/16 inch for Immediate Occupancy. (Tier 2: Sec. 4.3.3.12)
- C NC (N/A) CRACKS IN BOUNDARY COLUMNS: There shall be no existing diagonal cracks wider than 1/8 inch for Life Safety and 1/16 inch for Immediate Occupancy in concrete columns that encase masonry infills. (Tier 2: Sec. 4.3.3.13)

LATERAL-FORCE-RESISTING SYSTEM

Moment Frames ⇒ GRID 3 - Concrete MRF

General

GRID 6 - Steel MRF

GRID 8 - Concrete MRF

Ⓢ NC N/A

REDUNDANCY: The number of lines of moment frames in each principal direction shall be greater than or equal to 2 for Life Safety and Immediate Occupancy. The number of bays of moment frames in each line shall be greater than or equal to 2 for Life Safety and 3 for Immediate Occupancy. (Tier 2: Sec. 4.4.1.1.1) *At least 2 bays in MRF's*

Moment Frames with Infill Walls

C NC Ⓢ

INTERFERING WALLS: All concrete and masonry infill walls placed in moment frames shall be isolated from structural elements. (Tier 2: Sec. 4.4.1.2.1)

Steel Moment Frames - GRID 6 - Below West Shearwalls

C NC N/A
T.B.D.

DRIFT CHECK: The drift ratio of the steel moment frames, calculated using the Quick Check procedure of Section 3.5.3.1, shall be less than 0.025 for Life Safety and 0.015 for Immediate Occupancy. (Tier 2: Sec. 4.4.1.3.1)

C NC N/A
T.B.D.

AXIAL STRESS CHECK: The axial stress due to gravity loads in columns subjected to overturning forces shall be less than $0.10F_y$ for Life Safety and Immediate Occupancy. Alternatively, the axial stress due to overturning forces alone, calculated using the Quick Check procedure of Section 3.5.3.6, shall be less than $0.30F_y$ for Life Safety and Immediate Occupancy. (Tier 2: Sec. 4.4.1.3.2)

Concrete Moment Frames - GRID 3

GRID 8 - Below Stage

C Ⓢ N/A

SHEAR STRESS CHECK: The shear stress in the concrete columns, calculated using the Quick Check procedure of Section 3.5.3.2, shall be less than the greater of 100 psi or $2\sqrt{f'_c}$ for Life Safety and Immediate Occupancy. (Tier 2: Sec. 4.4.1.4.1)

C NC N/A
T.B.D.

AXIAL STRESS CHECK: The axial stress due to gravity loads in columns subjected to overturning forces shall be less than $0.10f'_c$ for Life Safety and Immediate Occupancy. Alternatively, the axial stresses due to overturning forces alone, calculated using the Quick Check procedure of Section 3.5.3.6, shall be less than $0.30f'_c$ for Life Safety and Immediate Occupancy. (Tier 2: Sec. 4.4.1.4.2)

Precast Concrete Moment Frames N/A

C NC Ⓢ

PRECAST CONNECTION CHECK: The precast connections at frame joints shall have the capacity to resist the shear and moment demands calculated using the Quick Check procedure of Section 3.5.3.5. (Tier 2: Sec. 4.4.1.5.1)

Frames Not Part of the Lateral-Force-Resisting System

Ⓢ NC N/A

COMPLETE FRAMES: Steel or concrete frames classified as secondary components shall form a complete vertical-load-carrying system. (Tier 2: Sec. 4.4.1.6.1)
Concrete columns and beams in both directions

Shear Walls

General

Ⓢ NC N/A

REDUNDANCY: The number of lines of shear walls in each principal direction shall be greater than or equal to 2 for Life Safety and Immediate Occupancy. (Tier 2: Sec. 4.4.2.1.1)

Screening Phase (Tier 1)

Concrete Shear Walls

- (C) NC N/A SHEAR STRESS CHECK: The shear stress in the concrete shear walls, calculated using the Quick Check procedure of Section 3.5.3.3, shall be less than the greater of 100 psi or $2\sqrt{f'_c}$ for Life Safety and Immediate Occupancy. (Tier 2: Sec. 4.4.2.2.1)
- C (NC) N/A REINFORCING STEEL: The ratio of reinforcing steel area to gross concrete area shall be not less than 0.0015 in the vertical direction and 0.0025 in the horizontal direction for Life Safety and Immediate Occupancy. The spacing of reinforcing steel shall be equal to or less than 18 inches for Life Safety and Immediate Occupancy. (Tier 2: Sec. 4.4.2.2.2)
- C NC (N/A) COLUMN SPLICES: Steel columns encased in shear-wall-boundary elements shall have splices that develop the tensile strength of the column. This statement shall apply to the Immediate Occupancy Performance Level only. (Tier 2: Sec. 4.4.2.2.9)

Precast Concrete Shear Walls N/A

- C NC (N/A) SHEAR STRESS CHECK: The shear stress in the precast panels, calculated using the Quick Check procedure of Section 3.5.3.3, shall be less than the greater of 100 psi or $2\sqrt{f'_c}$ for Life Safety and Immediate Occupancy. (Tier 2: Sec. 4.4.2.3.1)
- C NC (N/A) REINFORCING STEEL: The ratio of reinforcing steel area to gross concrete area shall be not less than 0.0015 in the vertical direction and 0.0025 in the horizontal direction for Life Safety and Immediate Occupancy. The spacing of reinforcing steel shall be equal to or less than 18 inches for Life Safety and Immediate Occupancy. (Tier 2: Sec. 4.4.2.3.2)

Reinforced Masonry Shear Walls - At Elevator Shaft
1965 Remodel

- C NC N/A T.B.D. SHEAR STRESS CHECK: The shear stress in the reinforced masonry shear walls, calculated using the Quick Check procedure of Section 3.5.3.3, shall be less than 70 psi for Life Safety and Immediate Occupancy. (Tier 2: Sec. 4.4.2.4.1)
- (C) NC N/A REINFORCING STEEL: The total vertical and horizontal reinforcing steel ratio in reinforced masonry walls shall be greater than 0.002 for Life Safety and Immediate Occupancy of the wall with the minimum of 0.0007 for Life Safety and Immediate Occupancy in either of the two directions; the spacing of reinforcing steel shall be less than 48 inches for Life Safety and Immediate Occupancy; and all vertical bars shall extend to the top of the walls. (Tier 2: Sec. 4.4.2.4.2)

Unreinforced Masonry Shear Walls N/A

- C NC (N/A) SHEAR STRESS CHECK: The shear stress in the unreinforced masonry shear walls, calculated using the Quick Check procedure of Section 3.5.3.3, shall be less than 30 psi for clay units and 70 psi for concrete units for Life Safety and Immediate Occupancy. (Tier 2: Sec. 4.4.2.5.1)

Infill Walls in Frames N/A

- C NC (N/A) WALL CONNECTIONS: Masonry shall be in full contact with frame for Life Safety and Immediate Occupancy. (Tier 2: Sec. 4.4.2.6.1)

Screening Phase (Tier 1)

Walls in Wood-Frame Buildings - *GRID 6, 1st & 2nd Story*

- C (NC) N/A SHEAR STRESS CHECK: The shear stress in the shear walls, calculated using the Quick Check procedure of Section 3.5.3.3, shall be less than the following values for Life Safety and Immediate Occupancy (Tier 2: Sec. 4.4.2.7.1):

Structural panel sheathing:	1,000 plf
Diagonal sheathing:	700 plf
→ Straight sheathing:	100 plf
→ All other conditions: <i>PLASTER</i>	100 plf
- C (NC) N/A STUCCO (EXTERIOR PLASTER) SHEAR WALLS: Multi-story buildings shall not rely on exterior stucco walls as the primary lateral-force-resisting system. (Tier 2: Sec. 4.4.2.7.2)
All exterior walls are concrete
- C (NC) N/A GYPSUM WALLBOARD OR PLASTER SHEAR WALLS: Interior plaster or gypsum wallboard shall not be used as shear walls on buildings over one story in height with the exception of the uppermost level of a multi-story building. (Tier 2: Sec. 4.4.2.7.3)
Grid 6 shear wall is metal lath and plaster
- C (NC) N/A NARROW WOOD SHEAR WALLS: Narrow wood shear walls with an aspect ratio greater than 2-to-1 for Life Safety and 1.5-to-1 for Immediate Occupancy shall not be used to resist lateral forces developed in the building in levels of moderate and high seismicity. Narrow wood shear walls with an aspect ratio greater than 2-to-1 for Immediate Occupancy shall not be used to resist lateral forces developed in the building in levels of low seismicity. (Tier 2: Sec. 4.4.2.7.4)
- C (NC) N/A WALLS CONNECTED THROUGH FLOORS: Shear walls shall have interconnection between stories to transfer overturning and shear forces through the floor. (Tier 2: Sec. 4.4.2.7.5)
- C NC (N/A) HILLSIDE SITE: For structures that are taller on at least one side by more than one-half story due to a sloping site, all shear walls on the downhill slope shall have an aspect ratio less than 1-to-1 for Life Safety and 1-to-2 for Immediate Occupancy. (Tier 2: Sec. 4.4.2.7.6)
- C NC (N/A) CRIPPLE WALLS: Cripple walls below first-floor-level shear walls shall be braced to the foundation with wood structural panels. (Tier 2: Sec. 4.4.2.7.7)
- C NC (N/A) OPENINGS: Walls with openings greater than 80 percent of the length shall be braced with wood structural panel shear walls with aspect ratios of not more than 1.5-to-1 or shall be supported by adjacent construction through positive ties capable of transferring the lateral forces. (Tier 2: Sec. 4.4.2.7.8)

Braced Frames *N/A*

General

- C NC (N/A) REDUNDANCY: The number of lines of braced frames in each principal direction shall be greater than or equal to 2 for Life Safety and Immediate Occupancy. The number of braced bays in each line shall be greater than 2 for Life Safety and 3 for Immediate Occupancy. (Tier 2: Sec. 4.4.3.1.1)
- C NC (N/A) AXIAL STRESS CHECK: The axial stress in the diagonals, calculated using the Quick Check procedure of Section 3.5.3.4, shall be less than $0.50F_y$ for Life Safety and for Immediate Occupancy. (Tier 2: Sec. 4.4.3.1.2)
- C NC (N/A) COLUMN SPLICES: All column splice details located in braced frames shall develop the tensile strength of the column. This statement shall apply to the Immediate Occupancy Performance Level only. (Tier 2: Sec. 4.4.3.1.3)

DIAPHRAGMS

Precast Concrete Diaphragms N/A

- C NC (N/A) TOPPING SLAB: Precast concrete diaphragm elements shall be interconnected by a continuous reinforced concrete topping slab. (Tier 2: Sec. 4.5.5.1)

CONNECTIONS

Anchorage for Normal Forces

- (C) NC N/A WALL ANCHORAGE: Exterior concrete or masonry walls that are dependent on the diaphragm for lateral support shall be anchored for out-of-plane forces at each diaphragm level with steel anchors, reinforcing dowels, or straps that are developed into the diaphragm. Connections shall have adequate strength to resist the connection force calculated in the Quick Check procedure of Section 3.5.3.7. (Tier 2: Sec. 4.6.1.1)
- (C) NC N/A WOOD LEDGERS: The connection between the wall panels and the diaphragm shall not induce cross-grain bending or tension in the wood ledgers. (Tier 2: Sec. 4.6.1.2)

Shear Transfer

- C (NC) N/A TRANSFER TO SHEAR WALLS: Diaphragms shall be connected for transfer of loads to the shear walls for Life Safety and the connections shall be able to develop the lesser of the shear strength of the walls or diaphragms for Immediate Occupancy. (Tier 2 Sec. 4.6.2.1)
- C NC N/A TRANSFER TO STEEL FRAMES: Diaphragms shall be connected for transfer of loads to the steel frames for Life Safety, and the connections shall be able to develop the lesser of the strength of the frames or the diaphragms for Immediate Occupancy. (Tier 2: Sec. 4.6.2.2)
- C NC (N/A) TOPPING SLAB TO WALLS OR FRAMES: Reinforced concrete topping slabs that interconnect the precast concrete diaphragm elements shall be doweled for transfer of forces into the shear wall or frame elements for Life Safety, and the dowels shall be able to develop the lesser of the shear strength of the walls, frames, or slabs for Immediate Occupancy. (Tier 2: Sec. 4.6.2.3)

Vertical Components

- (C) NC N/A STEEL COLUMNS: The columns in lateral-force-resisting frames shall be anchored to the building foundation for Life Safety, and the anchorage shall be able to develop the lesser of the tensile capacity of the column, the tensile capacity of the lowest level column splice (if any), or the uplift capacity of the foundation, for Immediate Occupancy. (Tier 2: Sec. 4.6.3.1)
- (C) NC N/A CONCRETE COLUMNS: All concrete columns shall be doweled into the foundation for Life Safety, and the dowels shall be able to develop the tensile capacity of reinforcement in columns of lateral-force-resisting system for Immediate Occupancy. (Tier 2: Sec. 4.6.3.2)
- C NC (N/A) WOOD POSTS: There shall be a positive connection of wood posts to the foundation. (Tier 2: Sec. 4.6.3.3)
- (C) NC N/A WOOD SILLS: All wood sills shall be bolted to the foundation. (Tier 2: Sec. 4.6.3.4)
- (C) NC N/A FOUNDATION DOWELS: Wall reinforcement shall be doweled into the foundation for Life Safety, and the dowels shall be able to develop the lesser of the strength of the walls or the uplift capacity of the foundation for Immediate Occupancy. (Tier 2: Sec. 4.6.3.5)
- (C) NC N/A SHEAR-WALL-BOUNDARY COLUMNS: The shear-wall-boundary columns shall be anchored to the building foundation for Life Safety, and the anchorage shall be able to develop the tensile capacity of the column for Immediate Occupancy. (Tier 2: Sec. 4.6.3.6)

Screening Phase (Tier 1)

C NC (N/A) PRECAST WALL PANELS: Precast wall panels shall be connected to the foundation for Life Safety and the connections shall be able to develop the strength of the walls for Immediate Occupancy. (Tier 2: Sec. 4.6.3.7)

C NC (N/A) WALL PANELS: Metal, fiberglass, or cementitious wall panels shall be positively attached to the foundation for Life Safety and Immediate Occupancy. (Tier 2: Sec. 4.6.3.8)

Interconnection of Elements

(C) NC N/A GIRDER/COLUMN CONNECTION: There shall be a positive connection utilizing plates, connection hardware, or straps between the girder and the column support. (Tier 2: Sec. 4.6.4.1)

Panel Connections

C NC (N/A) ROOF PANELS: Metal, plastic, or cementitious roof panels shall be positively attached to the roof framing to resist seismic forces for Life Safety and Immediate Occupancy. (Tier 2: Sec. 4.6.5.1)

C NC (N/A) WALL PANELS: Metal, fiberglass, or cementitious wall panels shall be positively attached to the framing to resist seismic forces for Life Safety and Immediate Occupancy. (Tier 2: Sec. 4.6.5.2)

3.7.16S General Supplemental Structural Checklist

This General Supplemental Structural Checklist shall be completed where required by Table 3-2. The General Basic Structural Checklist shall be completed prior to completing this General Supplemental Structural Checklist.

LATERAL-FORCE-RESISTING SYSTEM

Moment Frames

Steel Moment Frames

- C NC N/A
TBD. MOMENT-RESISTING CONNECTIONS: All moment connections shall be able to develop the strength of the adjoining members or panel zones. (Tier 2: Sec. 4.4.1.3.3)
- C NC N/A
TBD PANEL ZONES: All panel zones shall have the shear capacity to resist the shear demand required to develop 0.8 times the sum of the flexural strengths of the girders framing in at the face of the column. (Tier 2: Sec. 4.4.1.3.4)
- C NC (N/A) COLUMN SPLICES: All column splice details located in moment-resisting frames shall include connection of both flanges and the web for Life Safety, and the splice shall develop the strength of the column for Immediate Occupancy. (Tier 2: Sec. 4.4.1.3.5) *No Splices*
- C NC N/A
TBD STRONG COLUMN/WEAK BEAM: The percentage of strong column/weak beam joints in each story of each line of moment-resisting frames shall be greater than 50 percent for Life Safety and Immediate Occupancy. (Tier 2: Sec. 4.4.1.3.6)
- C NC N/A
TBD COMPACT MEMBERS: All frame elements shall meet section requirements set forth by *Seismic Provisions for Structural Steel Buildings* Table 1-9-1 (AISC, 1997). (Tier 2: Sec. 4.4.1.3.7)
- C NC (N/A) BEAM PENETRATIONS: All openings in frame-beam webs shall be less than 1/4 of the beam depth and shall be located in the center half of the beams. This statement shall apply to the Immediate Occupancy Performance Level only. (Tier 2: Sec. 4.4.1.3.8)
- C NC (N/A) GIRDER FLANGE CONTINUITY PLATES: There shall be girder flange continuity plates at all moment-resisting frame joints. This statement shall apply to the Immediate Occupancy Performance Level only. (Tier 2: Sec. 4.4.1.3.9)
- C NC (N/A) OUT-OF-PLANE BRACING: Beam-column joints shall be braced out-of-plane. This statement shall apply to the Immediate Occupancy Performance Level only. (Tier 2: Sec. 4.4.1.3.10)
- C NC (N/A) BOTTOM FLANGE BRACING: The bottom flanges of beams shall be braced out-of-plane. This statement shall apply to the Immediate Occupancy Performance Level only. (Tier 2: Sec. 4.4.1.3.11)

Concrete Moment Frames

- C NC (N/A) FLAT SLAB FRAMES: The lateral-force-resisting system shall not be a frame consisting of columns and a flat slab/plate without beams. (Tier 2: Sec. 4.4.1.4.3)
- C NC (N/A) PRESTRESSED FRAME ELEMENTS: The lateral-force-resisting frames shall not include any prestressed or post-tensioned elements where the average prestress exceeds the lesser of 700 psi or $f'_c/6$ at potential hinge locations. The average prestress shall be calculated in accordance with the Quick Check procedure of Section 3.5.3.8. (Tier 2: Sec. 4.4.1.4.4)
- (C) NC N/A CAPTIVE COLUMNS: There shall be no columns at a level with height/depth ratios less than 50 percent of the nominal height/depth ratio of the typical columns at that level for Life Safety and 75 percent for Immediate Occupancy. (Tier 2: Sec. 4.4.1.4.5)

Screening Phase (Tier 1)

- | | | |
|------------------------|-----------|---|
| C
TBD | NC
N/A | NO SHEAR FAILURES: The shear capacity of frame members shall be able to develop the moment capacity at the ends of the members. (Tier 2: Sec. 4.4.1.4.6) |
| C
" | NC
N/A | STRONG COLUMN/WEAK BEAM: The sum of the moment capacity of the columns shall be 20 percent greater than that of the beams at frame joints. (Tier 2: Sec. 4.4.1.4.7) |
| C
Need Test Results | NC
N/A | BEAM BARS: At least two longitudinal top and two longitudinal bottom bars shall extend continuously throughout the length of each frame beam. At least 25 percent of the longitudinal bars provided at the joints for either positive or negative moment shall be continuous throughout the length of the members for Life Safety and Immediate Occupancy. (Tier 2: Sec. 4.4.1.4.8) |
| C
TBD | NC
N/A | COLUMN-BAR SPLICES: All column bar lap splice lengths shall be greater than $35d_b$ for Life Safety and $50d_b$ for Immediate Occupancy, and shall be enclosed by ties spaced at or less than $8d_b$ for Life Safety and Immediate Occupancy. Alternatively, column bars shall be spliced with mechanical couplers with a capacity of at least 1.25 times the nominal yield strength of the spliced bar. (Tier 2: Sec. 4.4.1.4.9) |
| C
Unknown | NC
N/A | BEAM-BAR SPLICES: The lap splices or mechanical couplers for longitudinal beam reinforcing shall not be located within $l_b/4$ of the joints and shall not be located in the vicinity of potential plastic hinge locations. (Tier 2: Sec. 4.4.1.4.10) |
| C
Need Test Result | NC
N/A | COLUMN-TIE SPACING: Frame columns shall have ties spaced at or less than $d/4$ for Life Safety and Immediate Occupancy throughout their length and at or less than $8d_b$ for Life Safety and Immediate Occupancy at all potential plastic hinge locations. (Tier 2: Sec. 4.4.1.4.11) |
| C
Need Test Results | NC
N/A | STIRRUP SPACING: All beams shall have stirrups spaced at or less than $d/2$ for Life Safety and Immediate Occupancy throughout their length. At potential plastic hinge locations, stirrups shall be spaced at or less than the minimum of $8d_b$ or $d/4$ for Life Safety and Immediate Occupancy. (Tier 2: Sec. 4.4.1.4.12) |
| C
Need Test Results | NC
N/A | JOINT REINFORCING: Beam-column joints shall have ties spaced at or less than $8d_b$ for Life Safety and Immediate Occupancy. (Tier 2: Sec. 4.4.1.4.13) |
| C | NC (N/A) | JOINT ECCENTRICITY: There shall be no eccentricities larger than 20 percent of the smallest column plan dimension between girder and column centerlines. This statement shall apply to the <u>Immediate Occupancy Performance Level only</u> . (Tier 2: Sec. 4.4.1.4.14) |
| C | NC (N/A) | STIRRUP AND TIE HOOKS: The beam stirrups and column ties shall be anchored into the member cores with hooks of 135° or more. This statement shall apply to the <u>Immediate Occupancy Performance Level only</u> . (Tier 2: Sec. 4.4.1.4.15) |

Precast Concrete Moment Frames

- | | | |
|---|----------|--|
| C | NC (N/A) | PRECAST FRAMES: For buildings with concrete shear walls, precast concrete frame elements shall not be considered as primary components for resisting lateral forces. (Tier 2: Sec. 4.4.1.5.2) |
| C | NC (N/A) | PRECAST CONNECTIONS: For buildings with concrete shear walls, the connection between precast frame elements such as chords, ties, and collectors in the lateral-force-resisting system shall develop the capacity of the connected members. (Tier 2: Sec. 4.4.1.5.3) |

Frames Not Part of the Lateral-Force-Resisting System

- | | | |
|----------|-----------|--|
| C
TBD | NC
N/A | DEFLECTION COMPATIBILITY: Secondary components shall have the shear capacity to develop the flexural strength of the components for Life Safety and shall meet the requirements of Sections 4.4.1.4.9, 4.4.1.4.10, 4.4.1.4.11, 4.4.1.4.12 and 4.4.1.4.15 for Immediate Occupancy. (Tier 2: Sec. 4.4.1.6.2) |
|----------|-----------|--|

Screening Phase (Tier 1)

- C NC (N/A) FLAT SLABS: Flat slabs/plates not part of lateral-force-resisting system shall have continuous bottom steel through the column joints for Life Safety and Immediate Occupancy. (Tier 2: Sec. 4.4.1.6.3)

Shear Walls

Concrete Shear Walls

- C NC (N/A) COUPLING BEAMS: The stirrups in coupling beams over means of egress shall be spaced at or less than $d/2$ and shall be anchored into the confined core of the beam with hooks of 135° or more for Life Safety. All coupling beams shall comply with the requirements above and shall have the capacity in shear to develop the uplift capacity of the adjacent wall for Immediate Occupancy. (Tier 2: Sec. 4.4.2.2.3)
- C NC (N/A) OVERTURNING: All shear walls shall have aspect ratios less than 4-to-1. Wall piers need not be considered. This statement shall apply to the Immediate Occupancy Performance Level only. (Tier 2: Sec. 4.4.2.2.4)
- C NC (N/A) CONFINEMENT REINFORCING: For shear walls with aspect ratios greater than 2-to-1, the boundary elements shall be confined with spirals or ties with spacing less than $8d_b$. This statement shall apply to the Immediate Occupancy Performance Level only. (Tier 2: Sec. 4.4.2.2.5)
- C NC (N/A) REINFORCING AT OPENINGS: There shall be added trim reinforcement around all wall openings with a dimension greater than three times the thickness of the wall. This statement shall apply to the Immediate Occupancy Performance Level only. (Tier 2: Sec. 4.4.2.2.6)
- C NC (N/A) WALL THICKNESS: Thickness of bearing walls shall not be less than $1/25$ the unsupported height or length, whichever is shorter, nor less than 4 inches. This statement shall apply to the Immediate Occupancy Performance Level only. (Tier 2: Sec. 4.4.2.2.7)
- (C) NC N/A WALL CONNECTIONS: There shall be a positive connection between the shear walls and the steel beams and columns for Life Safety and the connection shall be able to develop the strength of the walls for Immediate Occupancy. (Tier 2: Sec. 4.4.2.2.8)

Precast Concrete Shear Walls N/A

- C NC (N/A) WALL OPENINGS: The total width of openings along any perimeter wall line shall constitute less than 75 percent of the length of any perimeter wall for Life Safety and 50 percent for Immediate Occupancy with the wall piers having aspect ratios of less than 2-to-1 for Life Safety and Immediate Occupancy. (Tier 2: Sec. 4.4.2.3.3)
- C NC (N/A) CORNER OPENINGS: Walls with openings at a building corner larger than the width of a typical panel shall be connected to the remainder of the wall with collector reinforcing. (Tier 2: Sec. 4.4.2.3.4)
- C NC (N/A) PANEL-TO-PANEL CONNECTIONS: Adjacent wall panels shall be interconnected to transfer overturning forces between panels by methods other than welded steel inserts. This statement shall apply to the Immediate Occupancy Performance Level only. (Tier 2: Sec. 4.4.2.3.5)
- C NC (N/A) WALL THICKNESS: Thickness of bearing walls shall not be less than $1/25$ the unsupported height or length, whichever is shorter, nor less than 4 inches. This statement shall apply to the Immediate Occupancy Performance Level only. (Tier 2: Sec. 4.4.2.3.6)

Reinforced Masonry Shear Walls

- C NC (N/A) REINFORCING AT OPENINGS: All wall openings that interrupt rebar shall have trim reinforcing on all sides. This statement shall apply to the Immediate Occupancy Performance Level only. (Tier 2: Sec. 4.4.2.4.3)

21

Screening Phase (Tier 1)

- C NC (N/A) PROPORTIONS: The height-to-thickness ratio of the shear walls at each story shall be less than 30. This statement shall apply to the Immediate Occupancy Performance Level only. (Tier 2: Sec. 4.4.2.4.4)

Unreinforced Masonry Shear Walls N/A

- C NC (N/A) PROPORTIONS: The height-to-thickness ratio of the shear walls at each story shall be less than the following for Life Safety and Immediate Occupancy (Tier 2: Sec. 4.4.2.5.2):

Top story of multi-story building:	9
First story of multi-story building:	15
All other conditions:	13

- C NC (N/A) MASONRY LAY-UP: Filled collar joints of multi-wythe masonry walls shall have negligible voids. (Tier 2: Sec. 4.4.2.5.3)

Infill Walls in Frames N/A

- C NC (N/A) PROPORTIONS: The height-to-thickness ratio of the infill walls at each story shall be less than 9 for Life Safety in levels of high seismicity, 13 for Immediate Occupancy in levels of moderate seismicity, and 8 for Immediate Occupancy in levels of high seismicity. (Tier 2: Sec. 4.4.2.6.2)

- C NC (N/A) SOLID WALLS: The infill walls shall not be of cavity construction. (Tier 2: Sec. 4.4.2.6.3)

- C NC (N/A) INFILL WALLS: The infill walls shall be continuous to the soffits of the frame beams and to the columns to either side. (Tier 2: Sec. 4.4.2.6.4)

Walls in Wood-Frame Buildings

- C NC (N/A) HOLD-DOWN ANCHORS: All shear walls shall have hold-down anchors constructed per acceptable construction practices, attached to the end studs. This statement shall apply to the Immediate Occupancy Performance Level only. (Tier 2: Sec. 4.4.2.7.9)

Braced Frames N/A

General

- C NC (N/A) SLENDERNESS OF DIAGONALS: All diagonal elements required to carry compression shall have Kl/r ratios less than 120. (Tier 2: Sec. 4.4.3.1.4)

- C NC (N/A) CONNECTION STRENGTH: All the brace connections shall develop the yield capacity of the diagonals. (Tier 2: Sec. 4.4.3.1.5)

- C NC (N/A) OUT-OF-PLANE BRACING: Braced frame connections attached to beam bottom flanges located away from beam-column joints shall be braced out-of-plane at the bottom flange of the beams. This statement shall apply to the Immediate Occupancy Performance Level only. (Tier 2: Sec. 4.4.3.1.6)

21

Screening Phase (Tier 1)

Concentrically Braced Frames N/A

- C NC (N/A) K-BRACING: The bracing system shall not include K-braced bays. (Tier 2: Sec. 4.4.3.2.1)
- C NC (N/A) TENSION-ONLY BRACES: Tension-only braces shall not comprise more than 70 percent of the total lateral-force-resisting capacity in structures over two stories in height. This statement shall apply to the Immediate Occupancy Performance Level only. (Tier 2: Sec. 4.4.3.2.2)
- C NC (N/A) CHEVRON BRACING: The bracing system shall not include chevron, or V-braced, bays. This statement shall apply to the Immediate Occupancy Performance Level only. (Tier 2: Sec. 4.4.3.2.3)
- C NC (N/A) CONCENTRICALLY BRACED FRAME JOINTS: All the diagonal braces shall frame into the beam-column joints concentrically. This statement shall apply to the Immediate Occupancy Performance Level only. (Tier 2: Sec. 4.4.3.2.4)

DIAPHRAGMS

General

- C (NC) N/A DIAPHRAGM CONTINUITY: The diaphragms shall not be composed of split-level floors and shall not have expansion joints. (Tier 2: Sec. 4.5.1.1)
- (C) NC N/A CROSS TIES: There shall be continuous cross ties between diaphragm chords. (Tier 2: Sec. 4.5.1.2)
- (C) NC N/A ROOF CHORD CONTINUITY: All chord elements shall be continuous, regardless of changes in roof elevation. (Tier 2: Sec. 4.5.1.3)
- (C) NC N/A OPENINGS AT SHEAR WALLS: Diaphragm openings immediately adjacent to the shear walls shall be less than 25 percent of the wall length for Life Safety and 15 percent of the wall length for Immediate Occupancy. (Tier 2: Sec. 4.5.1.4)
- C NC (N/A) OPENINGS AT BRACED FRAMES: Diaphragm openings immediately adjacent to the braced frames shall extend less than 25 percent of the frame length for Life Safety and 15 percent of the frame length for Immediate Occupancy. (Tier 2: Sec. 4.5.1.5)
- C NC (N/A) OPENINGS AT EXTERIOR MASONRY SHEAR WALLS: Diaphragm openings immediately adjacent to exterior masonry shear walls shall not be greater than 8 feet long for Life Safety and 4 feet long for Immediate Occupancy. (Tier 2: Sec. 4.5.1.6)
- C NC (N/A) PLAN IRREGULARITIES: There shall be tensile capacity to develop the strength of the diaphragm at re-entrant corners or other locations of plan irregularities. This statement shall apply to the Immediate Occupancy Performance Level only. (Tier 2: Sec. 4.5.1.7)
- C NC (N/A) DIAPHRAGM REINFORCEMENT AT OPENINGS: There shall be reinforcing around all diaphragm openings larger than 50 percent of the building width in either major plan dimension. This statement shall apply to the Immediate Occupancy Performance Level only. (Tier 2: Sec. 4.5.1.8)

Screening Phase (Tier 1)

Wood Diaphragms

- (C) NC N/A STRAIGHT SHEATHING: All straight sheathed diaphragms shall have aspect ratios less than 2-to-1 for Life Safety and 1-to-1 for Immediate Occupancy in the direction being considered. (Tier 2: Sec. 4.5.2.1)
- C (NC) N/A SPANS: All wood diaphragms with spans greater than 24 feet for Life Safety and 12 feet for Immediate Occupancy shall consist of wood structural panels or diagonal sheathing. Wood commercial and industrial buildings may have rod-braced systems. (Tier 2: Sec. 4.5.2.2)
- C NC (N/A) UNBLOCKED DIAPHRAGMS: All diagonally sheathed or unblocked wood structural panel diaphragms shall have horizontal spans less than 40 feet for Life Safety and 30 feet for Immediate Occupancy and shall have aspect ratios less than or equal to 4-to-1 for Life Safety and 3-to-1 for Immediate Occupancy. (Tier 2: Sec. 4.5.2.3)

Metal Deck Diaphragms N/A

- C NC (N/A) NON-CONCRETE FILLED DIAPHRAGMS: Untopped metal deck diaphragms or metal deck diaphragms with fill other than concrete shall consist of horizontal spans of less than 40 feet and shall have span/depth ratios less than 4-to-1. This statement shall apply to the Immediate Occupancy Performance Level only. (Tier 2: Sec. 4.5.3.1)

Other Diaphragms N/A

- C NC (N/A) OTHER DIAPHRAGMS: The diaphragm shall not consist of a system other than wood, metal deck, concrete, or horizontal bracing. (Tier 2: Sec. 4.5.7.1)

CONNECTIONS

Anchorage For Normal Forces

- C NC (N/A) PRECAST PANEL CONNECTIONS: There shall be at least two anchors from each precast wall panel into the diaphragm elements for Life Safety and the anchors shall be able to develop the strength of the panels for Immediate Occupancy. (Tier 2: Sec. 4.6.1.3)
- (C) NC N/A STIFFNESS OF WALL ANCHORS: Anchors of concrete or masonry walls to wood structural elements shall be installed taut and shall be stiff enough to limit the relative movement between the wall and the diaphragm to no greater than 1/8 inch prior to engagement of the anchors. (Tier 2: Sec. 4.6.1.4)

Vertical Components

- (C) NC N/A WOOD SILL BOLTS: Sill bolts shall be spaced at 6 feet or less for Life Safety and 4 feet or less for Immediate Occupancy, with proper edge and end distance provided for wood and concrete. (Tier 2: Sec. 4.6.3.9)
- C NC (N/A) UPLIFT AT PILE CAPS: Pile caps shall have top reinforcement and piles shall be anchored to the pile caps for Life Safety, and the pile cap reinforcement and pile anchorage shall be able to develop the tensile capacity of the piles for Immediate Occupancy. (Tier 2: Sec. 4.6.3.10)

Screening Phase (Tier 1)

Interconnection Of Elements

- C NC (N/A) GIRDERS: Girders supported by walls or pilasters shall have at least two ties securing the anchor bolts for Life Safety and Immediate Occupancy. (Tier 2: Sec. 4.6.4.2)
- C NC (N/A) CORBEL BEARING: If the frame girders bear on column corbels, the length of bearing shall be greater than 3 inches for Life Safety and Immediate Occupancy. (Tier 2: Sec. 4.6.4.3)
- C NC (N/A) CORBEL CONNECTIONS: The frame girders shall not be connected to corbels with welded elements. (Tier 2: Sec. 4.6.4.4)
- C NC (N/A) BEAM, GIRDER, AND TRUSS SUPPORTS: Beams, girders, and trusses supported by unreinforced masonry walls or pilasters shall have independent secondary columns for support of vertical loads. (Tier 2: Sec. 4.6.4.5)

Panel Connections

- C NC (N/A) ROOF PANEL CONNECTIONS: Roof panel connections shall be spaced at or less than 12 inches for Life Safety and 8 inches for Immediate Occupancy. (Tier 2: Sec. 4.6.5.3)

3.8 Geologic Site Hazards and Foundations Checklist

This Geologic Site Hazards and Foundations Checklist shall be completed where required by Table 3-2.

Each of the evaluation statements on this checklist shall be marked Compliant (C), Non-compliant (NC), or Not Applicable (N/A) for a Tier 1 Evaluation. Compliant statements identify issues that are acceptable according to the criteria of this standard, while non-compliant statements identify issues that require further investigation. Certain statements may not apply to the buildings being evaluated. For non-compliant evaluation statements, the design professional may choose to conduct further investigation using the corresponding Tier 2 Evaluation procedure; corresponding section numbers are in parentheses following each evaluation statement.

Geologic Site Hazards

The following statements shall be completed for buildings in levels of high or moderate seismicity.

- C NC N/A LIQUEFACTION: Liquefaction-susceptible, saturated, loose granular soils that could jeopardize the building's seismic performance shall not exist in the foundation soils at depths within 50 feet under the building for Life Safety and Immediate Occupancy. (Tier 2: Sec. 4.7.1.1)
- C NC N/A SLOPE FAILURE: The building site shall be sufficiently remote from potential earthquake-induced slope failures or rockfalls to be unaffected by such failures or shall be capable of accommodating any predicted movements without failure. (Tier 2: Sec. 4.7.1.2)
- C NC N/A SURFACE FAULT RUPTURE: Surface fault rupture and surface displacement at the building site is not anticipated. (Tier 2: Sec. 4.7.1.3)

Condition of Foundations

The following statement shall be completed for all Tier 1 building evaluations.

- C NC N/A FOUNDATION PERFORMANCE: There shall be no evidence of excessive foundation movement such as settlement or heave that would affect the integrity or strength of the structure. (Tier 2: Sec. 4.7.2.1)

The following statement shall be completed for buildings in levels of high or moderate seismicity being evaluated to the Immediate Occupancy Performance Level.

- C NC N/A DETERIORATION: There shall not be evidence that foundation elements have deteriorated due to corrosion, sulfate attack, material breakdown, or other reasons in a manner that would affect the integrity or strength of the structure. (Tier 2: Sec. 4.7.2.2)

Capacity of Foundations

The following statement shall be completed for all Tier 1 building evaluations.

- C NC N/A POLE FOUNDATIONS: Pole foundations shall have a minimum embedment depth of 4 feet for Life Safety and Immediate Occupancy. (Tier 2: Sec. 4.7.3.1)

The following statements shall be completed for buildings in levels of moderate seismicity being evaluated to the Immediate Occupancy Performance Level and for buildings in levels of high seismicity.

- C NC N/A OVERTURNING: The ratio of the horizontal dimension of the lateral-force-resisting system at the foundation level to the building height (base/height) shall be greater than 0.6S_w. (Tier 2: Sec. 4.7.3.2)

$(0.6)(0.96) = 0.576$

Screening Phase (Tier 1)

- C (NC) N/A TIES BETWEEN FOUNDATION ELEMENTS: The foundation shall have ties adequate to resist seismic forces where footings, piles, and piers are not restrained by beams, slabs, or soils classified as Class A, B, or C. (Section 3.5.2.3.1, Tier 2: Sec. 4.7.3.3)
- C NC (N/A) DEEP FOUNDATIONS: Piles and piers shall be capable of transferring the lateral forces between the structure and the soil. This statement shall apply to the Immediate Occupancy Performance Level only. (Tier 2: Sec. 4.7.3.4)
- C NC (N/A) SLOPING SITES: The difference in foundation embedment depth from one side of the building to another shall not exceed one story in height. This statement shall apply to the Immediate Occupancy Performance Level only. (Tier 2: Sec. 4.7.3.5)

3.9.1 Basic Nonstructural Component Checklist

This Basic Nonstructural Component Checklist shall be completed where required by Table 3-2.

Each of the evaluation statements on this checklist shall be marked Compliant (C), Non-compliant (NC), or Not Applicable (N/A) for a Tier 1 Evaluation. Compliant statements identify issues that are acceptable according to the criteria of this standard, while non-compliant statements identify issues that require further investigation. Certain statements may not apply to the buildings being evaluated. For non-compliant evaluation statements, the design professional may choose to conduct further investigation using the corresponding Tier 2 Evaluation procedure; corresponding section numbers are in parentheses following each evaluation statement.

Partitions

- C (NC) N/A UNREINFORCED MASONRY: Unreinforced masonry or hollow clay tile partitions shall be braced at a spacing equal to or less than 40 feet in levels of low or moderate seismicity and 6 feet in levels of high seismicity. (Tier 2: Sec. 4.8.1.1) URM clay tile in Boiler Rm.

Ceiling Systems

- C (NC) N/A SUPPORT: The integrated suspended ceiling system shall not be used to laterally support the tops of gypsum board, masonry, or hollow clay tile partitions. ~~Gypsum board partitions need not be evaluated where only the Basic Nonstructural Component Checklist is required by Table 3-2.~~ (Tier 2: Sec. 4.8.2.1) Suspended CLG in basement Men's Rm NC. Suspended CLG in Main Floor Bathrooms Vert Wires Diag. Wires incidental

Light Fixtures

- C (NC) N/A EMERGENCY LIGHTING: Emergency lighting shall be anchored or braced to prevent falling during an earthquake. (Tier 2: Sec. 4.8.3.1)

Cladding and Glazing

- C NC (N/A) CLADDING ANCHORS: Cladding components weighing more than 10 psf shall be mechanically anchored to the exterior wall framing at a spacing equal to or less than 4 feet. ~~A spacing of up to 6 feet is permitted where only the Basic Nonstructural Component Checklist is required by Table 3-2.~~ (Tier 2: Sec. 4.8.4.1)
- C NC (N/A) DETERIORATION: There shall be no evidence of deterioration, damage or corrosion in any of the connection elements. (Tier 2: Sec. 4.8.4.2)
- C NC (N/A) CLADDING ISOLATION: For moment frame buildings of steel or concrete, panel connections shall be detailed to accommodate a story drift ratio of 0.02. ~~Panel connection detailing for a story drift ratio of 0.01 is permitted where only the Basic Nonstructural Component Checklist is required by Table 3-2.~~ (Tier 2: Sec. 4.8.4.3)
- C NC (N/A) MULTI-STORY PANELS: For multi-story panels attached at each floor level, panel connections shall be detailed to accommodate a story drift ratio of 0.02. ~~Panel connection detailing for a story drift ratio of 0.01 is permitted where only the Basic Nonstructural Component Checklist is required by Table 3-2.~~ (Tier 2: Sec. 4.8.4.4)
- C NC (N/A) BEARING CONNECTIONS: Where bearing connections are required, there shall be a minimum of two bearing connections for each wall panel. (Tier 2: Sec. 4.8.4.5)

Screening Phase (Tier 1)

- C NC (N/A) INSERTS: Where inserts are used in concrete connections, the inserts shall be anchored to reinforcing steel or other positive anchorage. (Tier 2: Sec. 4.8.4.6)
- C NC (N/A) PANEL CONNECTIONS: Exterior cladding panels shall be anchored out-of-plane with a minimum of 4 connections for each wall panel. ~~Two connections per wall panel are permitted where only the Basic Nonstructural Component Checklist is required by Table 3-2.~~ (Tier 2: Sec. 4.8.4.7)

Masonry Veneer

- C NC (N/A) SHELF ANGLES: Masonry veneer shall be supported by shelf angles or other elements at each floor 30 feet or more above ground for Life Safety and at each floor above the first floor for Immediate Occupancy. (Tier 2: Sec. 4.8.5.1)
- C NC (N/A) TIES: Masonry veneer shall be connected to the back-up with corrosion-resistant ties. The ties shall have a spacing equal to or less than 24 inches with a minimum of one tie for every 2-2/3 square feet. ~~A spacing of up to 36 inches is permitted where only the Basic Nonstructural Component Checklist is required by Table 3-2.~~ (Tier 2: Sec. 4.8.5.2)
- C NC (N/A) WEAKENED PLANES: Masonry veneer shall be anchored to the back-up adjacent to weakened planes, such as at the locations of flashing. (Tier 2: Sec. 4.8.5.3)
- C NC (N/A) DETERIORATION: There shall be no evidence of deterioration, damage, or corrosion in any of the connection elements. (Tier 2: Sec. 4.8.5.4)

Parapets, Cornices, Ornamentation, and Appendages

- C NC (N/A) URM PARAPETS: There shall be no laterally unsupported unreinforced masonry parapets or cornices with height-to-thickness ratios greater than 1.5. ~~A height to thickness ratio of up to 2.5 is permitted where only the Basic Nonstructural Component Checklist is required by Table 3-2.~~ (Tier 2: Sec. 4.8.8.1)

- C (NC) N/A CANOPIES: Canopies located at building exits shall be anchored to the structural framing at a spacing of 6 feet or less. ~~An anchorage spacing of up to 10 feet is permitted where only the Basic Nonstructural Component Checklist is required by Table 3-2.~~ (Tier 2: Sec. 4.8.8.2)

Exterior Balcony Anchors show signs of rust.

Masonry Chimneys

- C NC (N/A) URM CHIMNEYS: No unreinforced masonry chimney shall extend above the roof surface more than twice the least dimension of the chimney. ~~A height above the roof surface of up to three times the least dimension of the chimney is permitted where only the Basic Nonstructural Component Checklist is required by Table 3-2.~~ (Tier 2: Sec. 4.8.9.1)

Stairs

- C NC (N/A) URM WALLS: Walls around stair enclosures shall not consist of unbraced hollow clay tile or unreinforced masonry with a height-to-thickness ratio greater than 12-to-1. ~~A height to thickness ratio of up to 15 to 1 is permitted where only the Basic Nonstructural Component Checklist is required by Table 3-2.~~ (Tier 2: Sec. 4.8.10.1)
- C NC (N/A) STAIR DETAILS: In moment frame structures, the connection between the stairs and the structure shall not rely on shallow anchors in concrete. Alternatively, the stair details shall be capable of accommodating the drift calculated using the Quick Check procedure of Section 3.5.3.1 without including tension in the anchors. (Tier 2: Sec. 4.8.10.2)

Building Contents and Furnishing

- C (NC) N/A TALL NARROW CONTENTS: Contents over 4 feet in height with a height-to-depth or height-to-width ratio greater than 3-to-1 shall be anchored to the floor slab or adjacent structural walls. ~~A height-to-depth or height-to-width ratio of up to 4 to 1 is permitted where only the Basic Nonstructural Component Checklist is required by Table 3-2.~~ (Tier 2: Sec. 4.8.11.1)
Many tall narrow bookcases & displays not anchored.

Mechanical and Electrical Equipment

- C NC (N/A) EMERGENCY POWER: Equipment used as part of an emergency power system shall be mounted to maintain continued operation after an earthquake. (Tier 2: Sec. 4.8.12.1)
- C NC (N/A) HAZARDOUS MATERIAL EQUIPMENT: HVAC or other equipment containing hazardous material shall not have damaged supply lines or unbraced isolation supports. (Tier 2: Sec. 4.8.12.2)
- C (NC) N/A DETERIORATION: There shall be no evidence of deterioration, damage, or corrosion in any of the anchorage or supports of mechanical or electrical equipment. (Tier 2: Sec. 4.8.12.3)
- C (NC) N/A ATTACHED EQUIPMENT: Equipment weighing over 20 lb that is attached to ceilings, walls, or other supports 4 feet above the floor level shall be braced. (Tier 2: Sec. 4.8.12.4)
Hung but not braced

Piping

- C NC (N/A) FIRE SUPPRESSION PIPING: Fire suppression piping shall be anchored and braced in accordance with NFPA-13 (NFPA, 1996). (Tier 2: Sec. 4.8.13.1)
- C (NC) N/A FLEXIBLE COUPLINGS: Fluid, gas, and fire suppression piping shall have flexible couplings. (Tier 2: Sec. 4.8.13.2) *Not found*

Hazardous Materials Storage and Distribution

- C NC (N/A) TOXIC SUBSTANCES: Toxic and hazardous substances stored in breakable containers shall be restrained from falling by latched doors, shelf lips, wires, or other methods. (Tier 2: Sec. 4.8.15.1)
*Cleaning Supplies in Janitor's Rm.
 Paint in Closet.*

3.9.2 Intermediate Nonstructural Component Checklist

This Intermediate Nonstructural Component Checklist shall be completed where required by Table 3-2. The Basic Nonstructural Component Checklist shall be completed prior to completing this Intermediate Nonstructural Component Checklist.

Ceiling Systems

- C NC (N/A) LAY-IN TILES: Lay-in tiles used in ceiling panels located at exits and corridors shall be secured with clips. (Tier 2: Sec. 4.8.2.2)
- C NC (N/A) INTEGRATED CEILINGS: Integrated suspended ceilings at exits and corridors or weighing more than 2 pounds per square foot shall be laterally restrained with a minimum of four diagonal wires or rigid members attached to the structure above at a spacing equal to or less than 12 feet. (Tier 2: Sec. 4.8.2.3)
- C NC (N/A) SUSPENDED LATH AND PLASTER: Ceilings consisting of suspended lath and plaster or gypsum board shall be attached to resist seismic forces for every 12 square feet of area. (Tier 2: Sec. 4.8.2.4)

Light Fixtures

- (C) NC N/A INDEPENDENT SUPPORT: Light fixtures in suspended grid ceilings shall be supported independently of the ceiling suspension system by a minimum of two wires at diagonally opposite corners of the fixtures. (Tier 2: Sec. 4.8.3.2)

Cladding and Glazing

- C NC (N/A) GLAZING: Glazing in curtain walls and individual panes over 16 square feet in area, located up to a height of 10 feet above an exterior walking surface, shall have safety glazing. Such glazing located over 10 feet above an exterior walking surface shall be laminated annealed or laminated heat-strengthened safety glass or other glazing system that will remain in the frame when glass is cracked. (Tier 2: Sec. 4.8.4.8)

Parapets, Cornices, Ornamentation, and Appendages

- (C) NC N/A CONCRETE PARAPETS: Concrete parapets with height-to-thickness ratios greater than 2.5 shall have vertical reinforcement. (Tier 2: Sec. 4.8.8.3)
- C (NC) N/A APPENDAGES: Cornices, parapets, signs, and other appendages that extend above the highest point of anchorage to the structure or cantilever from exterior wall faces and other exterior wall ornamentation shall be reinforced and anchored to the structural system at a spacing equal to or less than 10 feet for Life Safety and ~~6 feet for Immediate Occupancy~~. This requirement need not apply to parapets or cornices compliant with Section 4.8.8.1 or 4.8.8.3. (Tier 2: Sec. 4.8.8.4)

Masonry Chimneys

- C (NC) N/A ANCHORAGE: Masonry chimneys shall be anchored at each floor level and the roof. (Tier 2: Sec. 4.8.9.2)

21

Mechanical and Electrical Equipment

C NC (N/A) VIBRATION ISOLATORS: Equipment mounted on vibration isolators shall be equipped with restraints or snubbers. (Tier 2: Sec. 4.8.12.5)

Ducts

C NC (N/A) STAIR AND SMOKE DUCTS: Stair pressurization and smoke control ducts shall be braced and shall have flexible connections at seismic joints. (Tier 2: Sec. 4.8.14.1)

21

APPENDIX D

PRELIMINARY GEOTECHNICAL ASSESMENT LETTER

- Preliminary Geotechnical Assessment Letter dated March 30,2010
Prepared by Bauldry Engineering Inc.

Bauldry Engineering, Inc.

CONSULTING GEOTECHNICAL ENGINEERS

718 SOQUEL AVENUE, SANTA CRUZ, CA 95062

(831) 457-1223

FAX (831) 457-1225

1014-SZ972-D63

March 30, 2010

County of Santa Cruz
c/o Streeter Group
2571 Main Street, Suite C
Soquel, CA 95073

Subject: Preliminary Geotechnical Assessment
The Veterans Memorial Building
846 Front Street
Santa Cruz, California

Dear Mr. Streeter,

The Veterans Memorial Building has been temporarily closed for potential safety reasons pending the outcome of the Structural Engineer's assessment. It is our understanding that the assessment is being performed in accordance with the guidelines outlined in ASCE-31, *Seismic Evaluation of Existing Buildings*, and ASCE-41, *Seismic Rehabilitation of Existing Buildings*.

Our geotechnical engineering services are being provided in a phased approach. The first phase, which consisted of a review of available geologic maps, a review of the geotechnical reports from nearby sites, a floor level survey and a hand augered exploratory boring to compare the soils and groundwater conditions encountered at the site with those mapped or depicted in the neighboring sites, has been completed. The findings and results of our Phase 1 geotechnical assessment are provided below.

LIQUEFACTION POTENTIAL

Liquefaction tends to occur typically in soils composed of loose sands and non-cohesive silts of restricted permeability. In order for liquefaction to occur there must be the proper soil type, soil saturation, and cyclic accelerations of sufficient magnitude to progressively increase the water pressures within the soil mass. Non-cohesive soil shear strength is developed by the point to point contact of the soil grains. As the water pressures increase in the void spaces surrounding the soil grains, the soil particles become supported more by the water than the point to point contact. When the water pressures increase sufficiently, the soil grains begin to lose contact with each other, resulting in the loss of shear strength and continuous deformation of the soil where the soil appears to liquefy.

The site has been mapped on the USGS "Map Showing Liquefaction Potential of Quaternary Deposits in Santa Cruz County" (Dupré 1989) as having a high potential for liquefaction.

The project site is mapped on the USGS Geologic Map of Santa Cruz County (Brabb 1989) as being underlain Alluvial Deposits (Qal; Holocene) typically consisting of unconsolidated heterogeneous moderately sorted silt and sand containing discontinuous lenses of clay and silty clay. Locally includes large amounts of gravel.

One hand augered exploratory boring was advanced in the courtyard off the north side of the Veterans Hall. The soils encountered consisted of approximately 40 inches of fill generally comprised of silty sand with gravel. The native soil encountered beneath the fill consisted of fine to coarse grained sand with scattered gravel and only a trace of silt and clay fines. The gravels were rounded to subrounded and up to 4 inches in diameter. Groundwater was encountered at a depth of approximately 8 feet below the ground surface, which equates to approximately 4½ feet below the top of the basement slab floor. The boring was terminated at a depth of 8 feet due to caving of the cohesionless sands.

Results of Review of Soils Reports Prepared for Nearby Sites

Location	Soil Type	Reported Liquefaction Potential
Flat Iron Building 1538 Pacific Avenue	Alluvial Sand and Gravel	Little Likelihood ⁽¹⁾
1537 Pacific Avenue	Alluvial Sand and Gravel	Moderately High
St. George Hotel 833 Front Street	Alluvial Sand and Gravel	High
1405 Pacific Avenue	Alluvial Sand and Gravel	High
(1) Based on our review of the test borings presented in the 1996 Soils Report, it is our opinion that under current liquefaction assessment procedures the soils underlying the Flat Iron site may be classified as liquefiable.		

Our initial screening analysis of this site including the nature of the subsurface soil, the location of the ground water table, the estimated ground accelerations and a review of the Soils Reports for neighboring projects leads to the conclusion that the liquefaction potential at the Veterans Memorial Building site is high. This initial conclusion could be verified and the potential effects of liquefaction could be assessed by a detailed subsurface investigation during Phase 2.

SEISMIC SHAKING AND CBC DESIGN PARAMETERS

The following peak ground accelerations (PGA) were obtained for the project site from the USGS Seismic Hazards Program online probabilistic assessment tool.

Probability of Exceedance	PGA
2% in 50 years	0.634g
5% in 50 years	0.504g
10% in 50 years	0.410g

The soil at the soil is a Type F soil. For Tier 1 evaluation purposes we are providing the following seismic design parameters for a Type E. soil.

2007 CBC Seismic Design Parameters for Tier 1 Purposes

Site Class	E – Soft Soil Profile	
Mapped Spectral Response Accelerations	$S_S = 1.500g$	(T = 0.2 sec.)
	$S_1 = 0.600g$	(T = 1.0 sec.)
Site Coefficients	$F_a = 0.9$	(T = 0.2 sec.)
	$F_v = 2.4$	(T = 1.0 sec.)
Adjusted Maximum Considered Earthquake Spectral Response Acceleration Parameters	$S_{MS} = 1.350g$	(T = 0.2 sec.)
	$S_{M1} = 1,440g$	(T = 1.0 sec.)
Design Spectral Response Acceleration Parameters	$S_{DS} = 0.900g$	(T = 0.2 sec.)
	$S_{D1} = 0.960g$	(T = 1.0 sec.)

FLOOR LEVEL SURVEY

Our field work for the floor level survey has been completed. Our preliminary assessment of the data indicates that differential settlement has occurred throughout the building. The building in general appears to have settled towards the north. The greatest magnitude of settlement has occurred in the area of the elevator in the central section of the north side. The floor along central area of the northern perimeter is on the order of 2½ to 3 inches lower than floor along central area of the southern perimeter. The 2nd and 3rd floors have similar settlement towards the elevator in the central area of the northern perimeter.

LANDSLIDING

The project site and surrounding areas are essentially flat. There are no significant slopes in the vicinity of the site. Landsliding is not a hazard associated with the project site.

March 30, 2010

FOUNDATION UPGRADE

If a foundation upgrade is required to satisfy the Life and Safety level of performance, our preliminary thoughts are to tie the existing footings together with tie-beams to form a structurally integrated rigid grid. A rigid grid would help mitigate future differential settlement due to liquefaction.

Underpinning the existing foundation to a depth below the liquefaction soils would be difficult due to a high ground water table, caving soils and limited access. A detailed geotechnical investigation would be required to provide detailed underpinning design and construction recommendations, if required.

Other solutions such as ground modification could be feasible but may have limited application and would require a detailed subsurface investigation.

If you have any questions concerning the data, conclusions, or recommendations presented in this report, please call our office.

Very truly yours,

Bauldry Engineering, Inc.

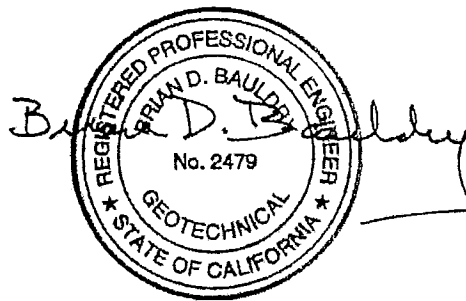

Brian D. Bauldry
Principal Engineer
G. E. 2479
Exp. 12/31/10

APPENDIX E

MR. PAUL COX LETTER DATED MARCH 4, 2010
WITH COMMENTARY

Commentary Regarding Mr. Cox's Letter:

Mr. Cox's letter dated March 4, 2010 provided a description of the building, possible explanation as to the cause of deterioration, noted observed distress and recommended action for occupancy. We agree with some of Mr. Cox's opinions but have a difference in opinion with regards to what constitutes a dangerous condition and therefore whether the building should be occupied or not.

Mr. Cox explains the observed spalling concrete is a result of the concrete losing its ability to protect the reinforcing steel over time due to the age of the building. We agree with this statement but do not rule out the possibility that some of the damage may have been the result of an earthquake. The observed location of some of the concrete distress coincides with where we would expect earthquake damage to occur. Earthquake induced cracks in the concrete could have provided a path for water intrusion into the concrete. We do not have any observed reports of the building after the Loma Preita earthquake but we do see evidence of previous attempts to patch damaged concrete.

Mr. Cox and we apparently disagree with what constitutes a dangerous condition. Mr. Cox points out the definition of dangerous terms such as "Imminent Treat" and "Distinct Hazard" and thinks they do not apply to this situation. In our opinion these definitions can be applied to the existing conditions such as the concrete columns supporting the stage addition which are structurally overstressed and distressed due to concrete damage. This condition does present a "Distinct Hazard" to the occupants of the building. It is an immediate danger should a seismic event occur.

Mr. Cox noted that we did not call for the building to be closed. The standard of care for professional engineers is to notify the building owner or local building official of the dangerous condition. We could have stated that the building should be closed but felt our letter clearly presented the danger of the building and stating that it be closed was not necessary.

We disagree with Mr. Cox that the building can be occupied during any evaluation or repair of the building. If the extent of the damage was minor and the building had a complete lateral load path system then possible one could accept some additional risk. But given the current condition of the building and given deficiencies in the lateral structural support system this building presents a dangerous condition.

Mr. Cox does state that the "building capacity should be carefully evaluated". He also states that "some level of seismic upgrade will likely be warranted". His statements are correct for we have identified several structural deficiencies in the lateral structural support of the building. Our findings further support our initial opinion of the building.

PAUL COX
890 Camelia Street
Berkeley, California 94710-1436
510-528-1975

COPY

March 4, 2010

Robert Patton, Commander
Veterans of Foreign Wars
Bill Motto Post 5888
846 Front Street
Santa Cruz, California 95060

Re: Santa Cruz Veterans Memorial Building

Dear Commander Patton,

This letter is to provide my observations and opinions on the condition of, and structural issues surrounding, the Santa Cruz Veterans Memorial Building that was suddenly closed by the County on January 21, 2010, due to County of Santa Cruz concerns over its structural safety. This letter is based on my site visit, my review of the January 21 letter by County staff, the January 18 letter by William Fisher Architecture, and the January 18 letter by the Streeter Group.

I am a California State licensed civil engineer and a 24-year member of the VFW Post 5888. I have 25 years experience across the United States specializing in investigation of existing buildings, including issues related to seismic loads, wind loads, overloads, fire, aging, historic preservation, repair design, and retrofit design.

On January 27, I visited the Santa Cruz Veterans Memorial Building at the request of VFW Post 5888, of which I am a member. I was escorted by Anthony Loero of Santa Cruz County General Services Department, William Fisher of William Fisher Architecture, Inc., and Hugh Zike of Streeter Group, Inc. These gentlemen graciously showed me around the building, pointed out the areas of concern and described their approach to the structural issues. Our inspection included the attic space over the auditorium, the roof, the auditorium, and the exterior walls on both sides and the rear of the building. I briefly looked at the original 1930s-era building drawings Mr. Fisher had with him. We did not inspect the basement or the front portion of the building as it was represented to me that these areas do not exhibit any visible damage conditions.

Other than removing a few pieces of loose concrete from exterior pilasters, I did not remove finishes to expose underlying conditions or perform destructive or non-destructive tests. I have not performed a mathematical analysis of the building. Other than as mentioned above I have not had the opportunity to review existing drawings or other documents related to the building. I base my opinions on 25 years' experience investigating and designing repairs to—and mitigations of—existing structures of all types, including many building of similar vintage and condition to the Veterans Building. The above caveats notwithstanding, I spent sufficient time at the building to form a firm and clear opinion as to its condition.

OBSERVATIONS

Building Description: All the building exterior walls and columns are steel-reinforced concrete, and it is likely that certain of the interior partitions are also. The floor, ceiling, and roof framing throughout the building are wood with heavy timber roof trusses and major beams. The building was constructed in the early

1930s except for the concrete stage structure at the back of the auditorium. Mr. Fisher believes the stage may have been added in the 1950s, but had not at the time of my visit found documentation to confirm it. The stage addition is about 15 feet deep. The original back wall of the auditorium was solid concrete, or nearly so, but about half the wall width has been removed to create the proscenium arch for the stage. The original concrete wall is intact above the proscenium arch, and is functionally now a deep beam, perhaps 8 feet tall. The nature of the reinforcement within this unintended beam is not known. The new back wall of the stage was erected over four short concrete columns. The nature of the stage's horizontal framing could not be determined during our visual survey. The auditorium sits over an equal-sized banquet room known as the bunker that is partially below grade. The side walls of the auditorium/bunker are concrete with windows. The four timber floor beams and four roof trusses that span the auditorium bear on four reinforced-concrete pilasters built into each side wall.

Roof Trusses: From our cursory inspection of the attic spaces, the heavy timber roof trusses and secondary lumber framing appear sound, with no indications of sag, decay, member splits, misalignment, or overloading damage. At least two of the trusses have steel brackets connecting the truss bearing points to the pilasters and side walls that appear to be retrofitted. We speculated that this work was installed at the time that trapeze anchors were installed on the trusses for the use by a community group in the auditorium. Messrs. Fisher and Zike had not identified any damage in the attic areas of the building.

County Observed Damage: As the letters from William Fisher Architecture and Streeter Group indicated, they have identified loose pieces of concrete on some of the eight pilasters along the north and south walls of the auditorium; loose concrete on some of the short columns under the back (west) wall of the stage; and corrosion to steel reinforcement under the loose concrete. They indicated that they had not found any other damage in the building that caused them concern, nor did I observe any other damage.

Spalling Concrete: I, too, observed loose concrete and corroded steel. Known as spalling, such loose concrete is not damage from overloading, or damage from seismic events, or poor quality concrete, or inadequate design, or poor construction. Instead, it is a deterioration process related simply to the age of the building and deferred maintenance.

The exposed concrete material itself appears to be in good condition; and it appears hard and properly colored, and the cracks split some of the aggregate, indicating that the cement paste and aggregate are sound.

Stirrups: Also in the pilasters, we observed some exposed horizontal steel stirrups that wrap around the vertical steel. These stirrups are open loops spaced about 24 inches apart in the areas we could see, and are typically 1/4-inch diameter smooth "pencil rods." One of these exposed rods has corroded through. I assume in his letter Mr. Streeter was referring to this rod that had "deteriorated completely in some locations."

Historic Building Code: Since the Santa Cruz Veterans Memorial Building is on the National Register of Historic Places, it is regulated by the 2007 California Historic Building Code, Part 8 of Title 24 (CHBC), for purposes of "preservation, restoration, rehabilitation...or reconstruction..." The intent of the CHBC is to "facilitate the preservation and continuing use of qualified historical buildings..." [my emphasis] Among other things, this code controls the terms under which this building can be declared hazardous. The CHBC defines terms pertinent to this discussion, as follows:

- "Life Safety Hazard: See Distinct Hazard"
- "Distinct Hazard: Any clear and evident condition that exists as an immediate danger to the safety of the occupants or public right of way. Conditions that do not meet the requirements of current regular codes and ordinances *do not*, of themselves, constitute a distinct hazard." [italics in original]

21

- "Imminent Threat: Any condition within or affecting a qualified historical building or property which, in the opinion of the authority having jurisdiction, would qualify a building or property as dangerous to the extent that the life, health, property or safety of the public, its occupants or those performing necessary repair, stabilization or shoring work are in immediate peril due to conditions affecting the building or property. Potential hazards to persons using, or improvements within, the right-of-way may not be construed to be "imminent threats" solely for that reason if the hazard can be mitigated by shoring, stabilization, barricades, or temporary fences."

In addition, Section 8-102.5 Unsafe buildings or Properties states, "When a qualified historical building... is determined to be unsafe as defined in the regular code, the requirements of the CHBC are applicable to the work necessary to correct the unsafe conditions. Work to remediate the buildings... need only address the correction of the unsafe conditions, and it shall not be required to bring the entire qualified historical building... into compliance with regular code."

For vertical loads, the CHBC structural section requires that, "The capacity of the structure to resist gravity loads shall be evaluated and the structure strengthened as necessary. The evaluation shall include all parts of the load path. Where no distress is evident, and a complete load path is present, the structure may be assumed adequate by having withstood the test of time..."

For seismic loads, the CHBC requires that the structure's ability to resist wind and seismic loads be evaluated, and that unsafe conditions in the lateral-load-resisting system be corrected to meet certain minimum strengths.

DISCUSSION

Spalling Mechanism: New concrete is extremely alkaline, and where concrete surrounds the reinforcing steel, the steel will be protected from corrosion. However, as reinforced concrete buildings age, there are gradual changes to the chemistry of the cement paste that have no effect on the concrete material strength but do reduce its alkalinity—eventually to the point that it no longer protects the steel. If oxygen and moisture are present, steel can then begin to corrode. When steel corrodes, the rust products swell to about six times the volume of the original steel. Concrete is strong in compression, but it is very weak in tension; so the internal tension forces from corrosion swelling soon overcome the concrete's tensile strength and cause it to crack (spall). This deterioration process accelerates after the concrete has cracked because it provides a channel for even more water and oxygen to reach the steel.

Eventually, chunks of concrete can be dislodged and fall from the building, exposing the underlying corroded steel. While this is a disturbing sight—and the public must be protected from falling debris—spalling is not, in itself, an indication that the building has become unsafe. It requires very little corrosion on the surface of steel reinforcement to blow off the overlying concrete. Typically the remaining cross-sectional area—and load-bearing capacity—of large bars is not significantly compromised simply because they have corroded enough to crack the concrete cover. My observation of the exposed vertical steel bars in the pilasters and columns at the Veterans Building is consistent with my past experience in that regard: the bars have destroyed the concrete cover in a few areas, but the bars themselves do not appear to have lost significant cross-sectional area. The very limited quantity of the obvious damage supports that contention. That is, by the time some of the bars have corroded enough to become compromised, the extent of the corrosion is normally exhibited over large areas, not just small corner spalls such as those present on the Veterans Building.

Additionally, when the strength of a reinforced column or beam is analyzed by engineers, the concrete cover to the outboard side of the reinforcement is neglected in the tension region. Thus, for the critical tension case,

the cover does not count structurally. The function of the concrete cover is to protect the steel from the weather, which is a serviceability issue, not a structural one.

The four columns and beams supporting the back wall of the stage are in the same condition as the pilasters: they have superficial spalling of the concrete cover due to corrosion of the underlying steel. Despite Mr. Fisher's assertion, there is no reason to replace any of the columns or beams.

It should be noted that if the concrete has is not cracked, there can be little corrosion of the underlying steel. Thus, in the areas of the building that are away from the existing spalls and are not cracked, the steel is likely to be in good condition.

Stirrups: Obviously, a small-diameter steel rod will corrode through much more quickly than a large-diameter one. However, to say that the complete corrosion of a small rod on a column is a significant structural matter is a significant overstatement. While modern ductile reinforced concrete design in seismic zones requires columns to have careful detailing and closely-spaced continuous-spiral stirrups, the need for such detailing was not understood when this building was designed. At that time, the sole purpose of an occasional loop of pencil rod was to hold the vertical steel in alignment within the forms until the concrete could be placed. Once the concrete was cured, the pencil rods were not expected to have any function whatsoever; and, in fact, because of their wide spacing, small diameter, discontinuity, and inability to provide confinement for the concrete, they contribute nothing to the serviceability, strength, or ductility of an in-service column. Thus, if one or a few of these rods are corroded through, it will have no influence whatsoever on the behavior of the column during the cyclic loads imposed by an earthquake.

Building Code Requirements: Mr. Streeter described "significant cracking" and "significant risk of injury or death...should a seismic event occur," but he did not call for the building to be closed. Mr. Fisher called the pilaster damage "extremely significant," described "extreme danger" for the public if an earthquake occurs, and called for the auditorium to be closed. While neither Mr. Fisher nor Mr. Streeter used any of the three CHBC hazard/terms listed above in their letters, they clearly intended to raise the alarm as to the seismic capacity of the building, but they did not identify an "imminent threat...due to conditions affecting the building." That is, they did not indicate that they thought the building could collapse under its own weight or normal live loads. As described above, it is my opinion that, while there is minor spalling at the pilasters, this does not constitute distress due to loading, nor does it affect gravity load-carrying capacity.

As for the seismic capacity, it is clear from its age, its design, and its condition that the building does not meet current code requirements for seismic capacity. For any building professional to suggest that it be investigated and upgraded is simply prudence. But, as defined by the CHBC, "distinct hazard" cannot exist merely because the building does not meet current regular codes. Similarly, "imminent threat" cannot exist if the hazard "can be mitigated by...stabilization [or] barricades."

Unoccupied Building Costs: As a practical matter, the County should keep in mind that uninhabited buildings often experience accelerated deterioration through a variety of mechanisms. Undetected leaks, vandalism, maintenance neglect, stagnant plumbing, rusted mechanical systems, condensation and mildew in unheated spaces, varmints, and other insults can result in much higher costs when the time comes to reoccupy a facility.

CONCLUSIONS

Instead of characterizing the observed damage to the steel and spalling concrete as "extremely significant," as Mr. Fisher did in his letter, I would characterize it as insignificant structurally, but a significant maintenance

issue that could—if left unrepaired—become significant structurally in years to come. Similarly, instead of indicating that the "deterioration observed presents a significant risk of injury or death to the occupants of the auditorium should a seismic event occur," as Mr. Streeter did in his letter, I would characterized the observed deterioration as an indication that the County should immediately move to protect the public from falling concrete by preventing people from leaning against the pilasters—which has already been accomplished by the judicious application of yellow tape. The observed deterioration itself in no other way presents significant risk. The building likely has seismic deficiencies; but these deficiencies are completely unrelated to the spalling, and the County should not conflate the two issues.

For existing vertical loads on the structure, it is my opinion that the observed damage to the concrete pilasters, walls, and columns is not significant, and in no way justifies closure of the building. In addition, the California Historic Building Code forbids its closure because neither a distinct hazard nor an imminent threat exist.

For potential seismic loads on the structure, I concur that the building capacity should be carefully evaluated. Given the archaic nature of the existing construction, some level of seismic upgrade will likely be warranted, but is not mandated by any code requirements. However, the mere existence of seismic-response deficiencies does not constitute a distinct hazard or an imminent threat as defined by the CHBC, because these deficiencies represent only potential hazards. While it may be necessary to empty the building during the construction of a seismic retrofit, it is my opinion that there is no justification for its closure based on the current condition of the building, nor will it be necessary to close the building during the evaluation or retrofit design phases.

Lastly, due diligence requires the County to let a contract on a non-emergency basis to repair the spalling concrete as part of a maintenance program—an easy, effective, and essentially permanent repair if properly conceived and installed. Again, this can be accomplished without closing the building.

I hope this letter has helped to clarify for you the condition of the Veterans' Building, and assists you in getting it reopened immediately.

Sincerely,



Paul Cox, C.E. 45152

COPY

PAUL COX
890 Camelia Street
Berkeley, California 94710-1436
510-528-1975

March 4, 2010

Robert Patton, Commander
Veterans of Foreign Wars
Bill Motto Post 5888
846 Front Street
Santa Cruz, California 95060

Re: Santa Cruz Veterans Memorial Building

Dear Commander Patton,

This letter is to provide my observations and opinions on the condition of, and structural issues surrounding, the Santa Cruz Veterans Memorial Building that was suddenly closed by the County on January 21, 2010, due to County of Santa Cruz concerns over its structural safety. This letter is based on my site visit, my review of the January 21 letter by County staff, the January 18 letter by William Fisher Architecture, and the January 18 letter by the Streeter Group.

I am a California State licensed civil engineer and a 24-year member of the VFW Post 5888. I have 25 years experience across the United States specializing in investigation of existing buildings, including issues related to seismic loads, wind loads, overloads, fire, aging, historic preservation, repair design, and retrofit design.

On January 27, I visited the Santa Cruz Veterans Memorial Building at the request of VFW Post 5888, of which I am a member. I was escorted by Anthony Loero of Santa Cruz County General Services Department, William Fisher of William Fisher Architecture, Inc., and Hugh Zike of Streeter Group, Inc. These gentlemen graciously showed me around the building, pointed out the areas of concern and described their approach to the structural issues. Our inspection included the attic space over the auditorium, the roof, the auditorium, and the exterior walls on both sides and the rear of the building. I briefly looked at the original 1930s-era building drawings Mr. Fisher had with him. We did not inspect the basement or the front portion of the building as it was represented to me that these areas do not exhibit any visible damage conditions.

Other than removing a few pieces of loose concrete from exterior pilasters, I did not remove finishes to expose underlying conditions or perform destructive or non-destructive tests. I have not performed a mathematical analysis of the building. Other than as mentioned above I have not had the opportunity to review existing drawings or other documents related to the building. I base my opinions on 25 years' experience investigating and designing repairs to—and mitigations of—existing structures of all types, including many building of similar vintage and condition to the Veterans Building. The above caveats notwithstanding, I spent sufficient time at the building to form a firm and clear opinion as to its condition.

OBSERVATIONS

Building Description: All the building exterior walls and columns are steel-reinforced concrete, and it is likely that certain of the interior partitions are also. The floor, ceiling, and roof framing throughout the building are wood with heavy timber roof trusses and major beams. The building was constructed in the early

1930s except for the concrete stage structure at the back of the auditorium. Mr. Fisher believes the stage may have been added in the 1950s, but had not at the time of my visit found documentation to confirm it. The stage addition is about 15 feet deep. The original back wall of the auditorium was solid concrete, or nearly so, but about half the wall width has been removed to create the proscenium arch for the stage. The original concrete wall is intact above the proscenium arch, and is functionally now a deep beam, perhaps 8 feet tall. The nature of the reinforcement within this unintended beam is not known. The new back wall of the stage was erected over four short concrete columns. The nature of the stage's horizontal framing could not be determined during our visual survey. The auditorium sits over an equal-sized banquet room known as the bunker that is partially below grade. The side walls of the auditorium/bunker are concrete with windows. The four timber floor beams and four roof trusses that span the auditorium bear on four reinforced-concrete pilasters built into each side wall.

Roof Trusses: From our cursory inspection of the attic spaces, the heavy timber roof trusses and secondary lumber framing appear sound, with no indications of sag, decay, member splits, misalignment, or overloading damage. At least two of the trusses have steel brackets connecting the truss bearing points to the pilasters and side walls that appear to be retrofitted. We speculated that this work was installed at the time that trapeze anchors were installed on the trusses for the use by a community group in the auditorium. Messrs. Fisher and Zike had not identified any damage in the attic areas of the building.

County Observed Damage: As the letters from William Fisher Architecture and Streeter Group indicated, they have identified loose pieces of concrete on some of the eight pilasters along the north and south walls of the auditorium; loose concrete on some of the short columns under the back (west) wall of the stage; and corrosion to steel reinforcement under the loose concrete. They indicated that they had not found any other damage in the building that caused them concern, nor did I observe any other damage.

Spalling Concrete: I, too, observed loose concrete and corroded steel. Known as spalling, such loose concrete is not damage from overloading, or damage from seismic events, or poor quality concrete, or inadequate design, or poor construction. Instead, it is a deterioration process related simply to the age of the building and deferred maintenance.

The exposed concrete material itself appears to be in good condition; and it appears hard and properly colored, and the cracks split some of the aggregate, indicating that the cement paste and aggregate are sound.

Stirrups: Also in the pilasters, we observed some exposed horizontal steel stirrups that wrap around the vertical steel. These stirrups are open loops spaced about 24 inches apart in the areas we could see, and are typically 1/4-inch diameter smooth "pencil rods." One of these exposed rods has corroded through. I assume in his letter Mr. Streeter was referring to this rod that had "deteriorated completely in some locations."

Historic Building Code: Since the Santa Cruz Veterans Memorial Building is on the National Register of Historic Places, it is regulated by the 2007 California Historic Building Code, Part 8 of Title 24 (CHBC), for purposes of "preservation, restoration, rehabilitation...or reconstruction..." The intent of the CHBC is to "facilitate the preservation and continuing use of qualified historical buildings..." [my emphasis] Among other things, this code controls the terms under which this building can be declared hazardous. The CHBC defines terms pertinent to this discussion, as follows:

- "Life Safety Hazard: See Distinct Hazard"
- "Distinct Hazard: Any clear and evident condition that exists as an immediate danger to the safety of the occupants or public right of way. Conditions that do not meet the requirements of current regular codes and ordinances *do not*, of themselves, constitute a distinct hazard." [italics in original]

- "Imminent Threat: Any condition within or affecting a qualified historical building or property which, in the opinion of the authority having jurisdiction, would qualify a building or property as dangerous to the extent that the life, health, property or safety of the public, its occupants or those performing necessary repair, stabilization or shoring work are in immediate peril due to conditions affecting the building or property. Potential hazards to persons using, or improvements within, the right-of-way may not be construed to be "imminent threats" solely for that reason if the hazard can be mitigated by shoring, stabilization, barricades, or temporary fences."

In addition, Section 8-102.5 Unsafe buildings or Properties states, "When a qualified historical building...is determined to be unsafe as defined in the regular code, the requirements of the CHBC are applicable to the work necessary to correct the unsafe conditions. Work to remediate the buildings...need only address the correction of the unsafe conditions, and it shall not be required to bring the entire qualified historical building...into compliance with regular code."

For vertical loads, the CHBC structural section requires that, "The capacity of the structure to resist gravity loads shall be evaluated and the structure strengthened as necessary. The evaluation shall include all parts of the load path. Where no distress is evident, and a complete load path is present, the structure may be assumed adequate by having withstood the test of time..."

For seismic loads, the CHBC requires that the structure's ability to resist wind and seismic loads be evaluated, and that unsafe conditions in the lateral-load-resisting system be corrected to meet certain minimum strengths.

DISCUSSION

Spalling Mechanism: New concrete is extremely alkaline, and where concrete surrounds the reinforcing steel, the steel will be protected from corrosion. However, as reinforced concrete buildings age, there are gradual changes to the chemistry of the cement paste that have no effect on the concrete material strength but do reduce its alkalinity—eventually to the point that it no longer protects the steel. If oxygen and moisture are present, steel can then begin to corrode. When steel corrodes, the rust products swell to about six times the volume of the original steel. Concrete is strong in compression, but it is very weak in tension; so the internal tension forces from corrosion swelling soon overcome the concrete's tensile strength and cause it to crack (spall). This deterioration process accelerates after the concrete has cracked because it provides a channel for even more water and oxygen to reach the steel.

Eventually, chunks of concrete can be dislodged and fall from the building, exposing the underlying corroded steel. While this is a disturbing sight—and the public must be protected from falling debris—spalling is not, in itself, an indication that the building has become unsafe. It requires very little corrosion on the surface of steel reinforcement to blow off the overlying concrete. Typically the remaining cross-sectional area—and load-bearing capacity—of large bars is not significantly compromised simply because they have corroded enough to crack the concrete cover. My observation of the exposed vertical steel bars in the pilasters and columns at the Veterans Building is consistent with my past experience in that regard: the bars have destroyed the concrete cover in a few areas, but the bars themselves do not appear to have lost significant cross-sectional area. The very limited quantity of the obvious damage supports that contention. That is, by the time some of the bars have corroded enough to become compromised, the extent of the corrosion is normally exhibited over large areas, not just small corner spalls such as those present on the Veterans Building.

Additionally, when the strength of a reinforced column or beam is analyzed by engineers, the concrete cover to the outboard side of the reinforcement is neglected in the tension region. Thus, for the critical tension case,

the cover does not count structurally. The function of the concrete cover is to protect the steel from the weather, which is a serviceability issue, not a structural one.

The four columns and beams supporting the back wall of the stage are in the same condition as the pilasters: they have superficial spalling of the concrete cover due to corrosion of the underlying steel. Despite Mr. Fisher's assertion, there is no reason to replace any of the columns or beams.

It should be noted that if the concrete has is not cracked, there can be little corrosion of the underlying steel. Thus, in the areas of the building that are away from the existing spalls and are not cracked, the steel is likely to be in good condition.

Stirrups: Obviously, a small-diameter steel rod will corrode through much more quickly than a large-diameter one. However, to say that the complete corrosion of a small rod on a column is a significant structural matter is a significant overstatement. While modern ductile reinforced concrete design in seismic zones requires columns to have careful detailing and closely-spaced continuous-spiral stirrups, the need for such detailing was not understood when this building was designed. At that time, the sole purpose of an occasional loop of pencil rod was to hold the vertical steel in alignment within the forms until the concrete could be placed. Once the concrete was cured, the pencil rods were not expected to have any function whatsoever; and, in fact, because of their wide spacing, small diameter, discontinuity, and inability to provide confinement for the concrete, they contribute nothing to the serviceability, strength, or ductility of an in-service column. Thus, if one or a few of these rods are corroded through, it will have no influence whatsoever on the behavior of the column during the cyclic loads imposed by an earthquake.

Building Code Requirements: Mr. Streeter described "significant cracking" and "significant risk of injury or death...should a seismic event occur," but he did not call for the building to be closed. Mr. Fisher called the pilaster damage "extremely significant," described "extreme danger" for the public if an earthquake occurs, and called for the auditorium to be closed. While neither Mr. Fisher nor Mr. Streeter used any of the three CHBC hazard terms listed above in their letters, they clearly intended to raise the alarm as to the seismic capacity of the building, but they did not identify an "imminent threat...due to conditions affecting the building." That is, they did not indicate that they thought the building could collapse under its own weight or normal live loads. As described above, it is my opinion that, while there is minor spalling at the pilasters, this does not constitute distress due to loading, nor does it affect gravity load-carrying capacity.

As for the seismic capacity, it is clear from its age, its design, and its condition that the building does not meet current code requirements for seismic capacity. For any building professional to suggest that it be investigated and upgraded is simply prudence. But, as defined by the CHBC, "distinct hazard" cannot exist merely because the building does not meet current regular codes. Similarly, "imminent threat" cannot exist if the hazard "can be mitigated by...stabilization [or] barricades."

Unoccupied Building Costs: As a practical matter, the County should keep in mind that uninhabited buildings often experience accelerated deterioration through a variety of mechanisms. Undetected leaks, vandalism, maintenance neglect, stagnant plumbing, rusted mechanical systems, condensation and mildew in unheated spaces, varmints, and other insults can result in much higher costs when the time comes to reoccupy a facility.

CONCLUSIONS

Instead of characterizing the observed damage to the steel and spalling concrete as "extremely significant," as Mr. Fisher did in his letter, I would characterize it as insignificant structurally, but a significant maintenance

March 4, 2010

issue that could—if left unrepaired—become significant structurally in years to come. Similarly, instead of indicating that the "deterioration observed presents a significant risk of injury or death to the occupants of the auditorium should a seismic event occur," as Mr. Streeter did in his letter, I would characterize the observed deterioration as an indication that the County should immediately move to protect the public from falling concrete by preventing people from leaning against the pilasters—which has already been accomplished by the judicious application of yellow tape. The observed deterioration itself in no other way presents significant risk. The building likely has seismic deficiencies; but these deficiencies are completely unrelated to the spalling, and the County should not conflate the two issues.

For existing vertical loads on the structure, it is my opinion that the observed damage to the concrete pilasters, walls, and columns is not significant, and in no way justifies closure of the building. In addition, the California Historic Building Code forbids its closure because neither a distinct hazard nor an imminent threat exist.

For potential seismic loads on the structure, I concur that the building capacity should be carefully evaluated. Given the archaic nature of the existing construction, some level of seismic upgrade will likely be warranted, but is not mandated by any code requirements. However, the mere existence of seismic-response deficiencies does not constitute a distinct hazard or an imminent threat as defined by the CHBC, because these deficiencies represent only potential hazards. While it may be necessary to empty the building during the construction of a seismic retrofit, it is my opinion that there is no justification for its closure based on the current condition of the building, nor will it be necessary to close the building during the evaluation or retrofit design phases.

Lastly, due diligence requires the County to let a contract on a non-emergency basis to repair the spalling concrete as part of a maintenance program—an easy, effective, and essentially permanent repair if properly conceived and installed. Again, this can be accomplished without closing the building.

I hope this letter has helped to clarify for you the condition of the Veterans' Building, and assists you in getting it reopened immediately.

Sincerely,



Paul Cox, C.E. 45152

21